

Milwaukee[®]

Nothing but **HEAVY DUTY**.[®]



M12 UDEL



Original instructions



2



3



$\varnothing 5 - 16 \text{ mm}$



$\varnothing 16 - 30 \text{ mm}$

4



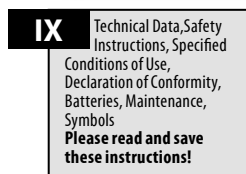
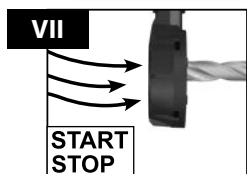
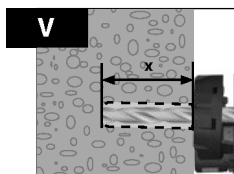
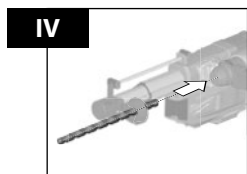
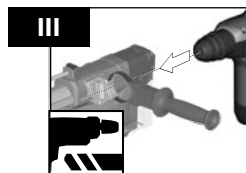
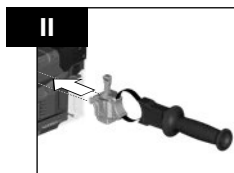
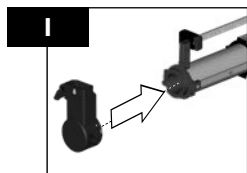

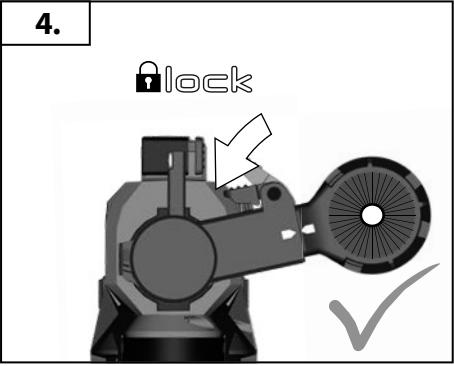
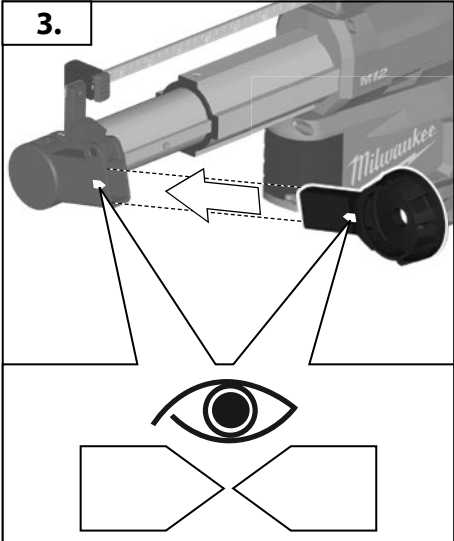
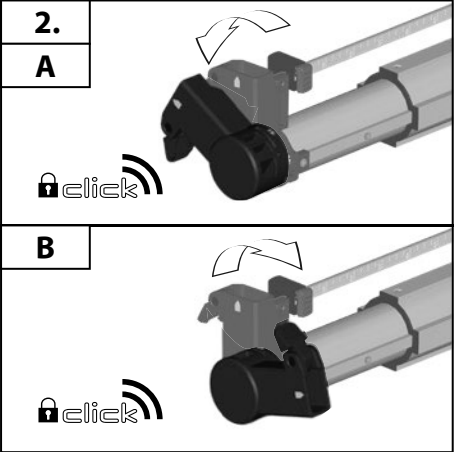
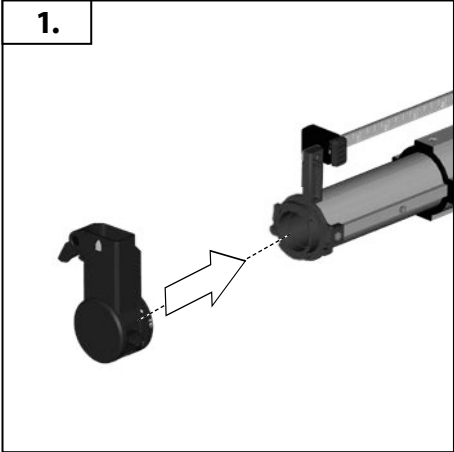
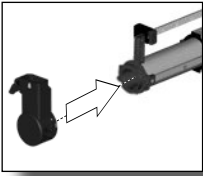

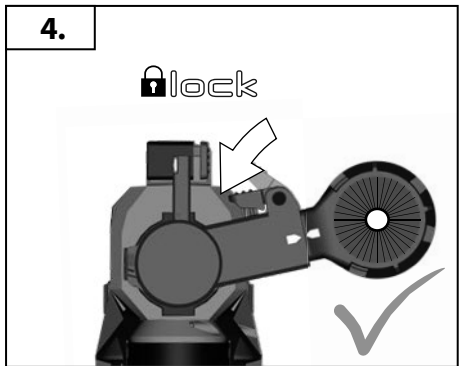
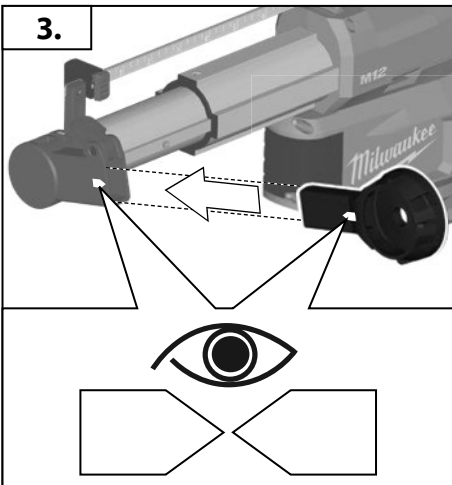
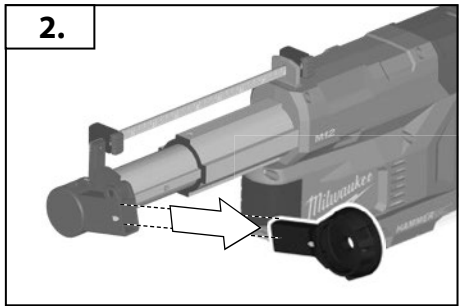
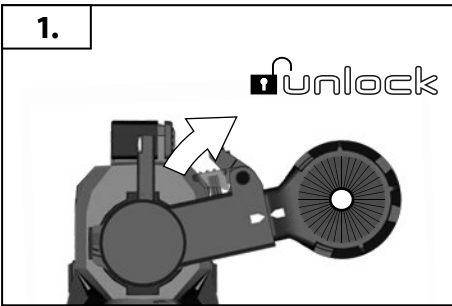
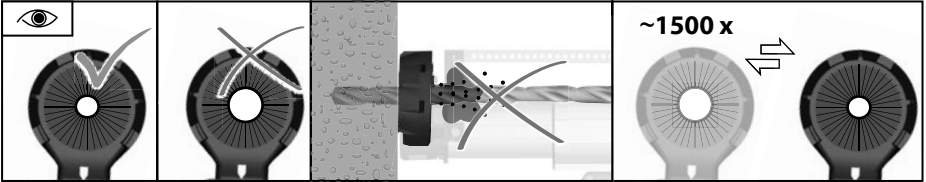
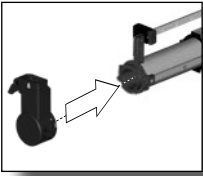

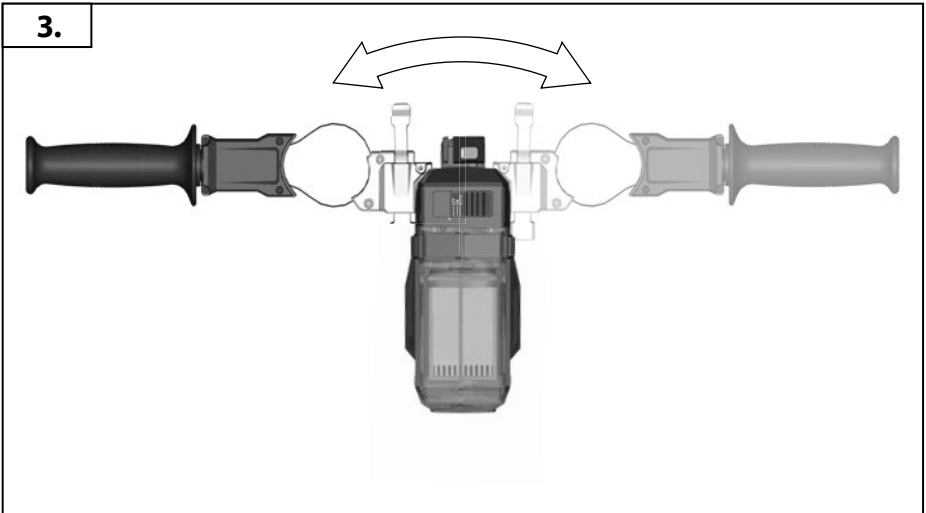
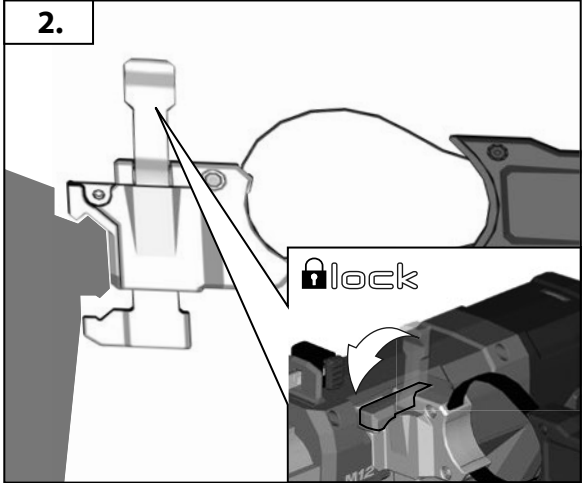
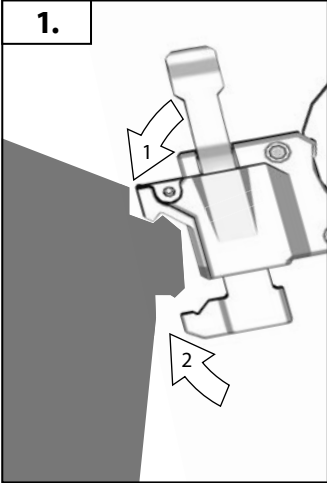
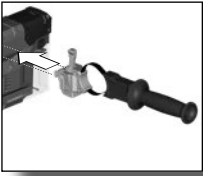

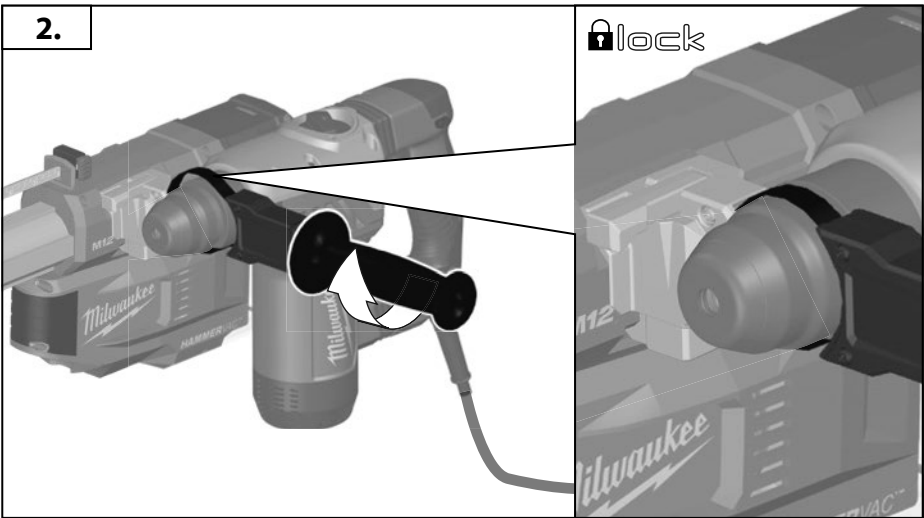
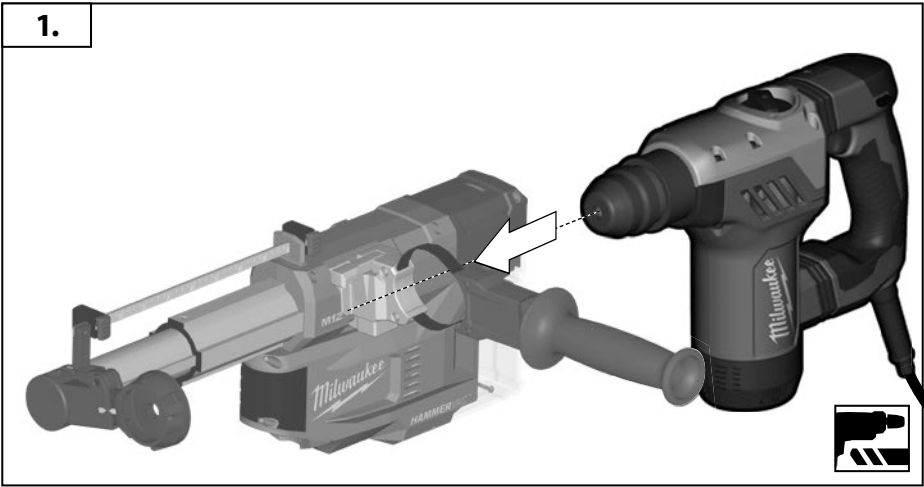
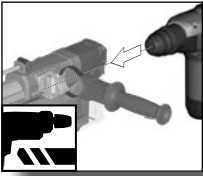

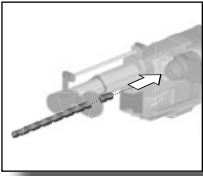

IV

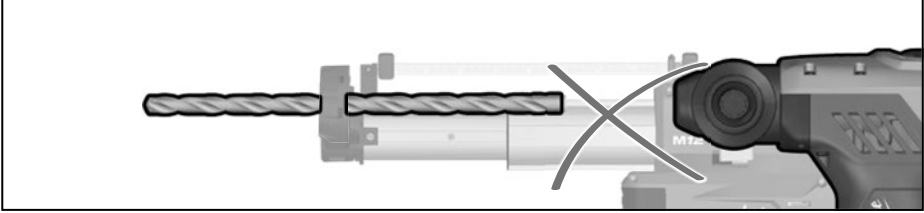
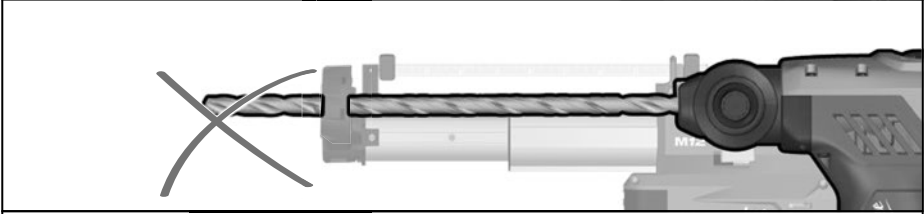
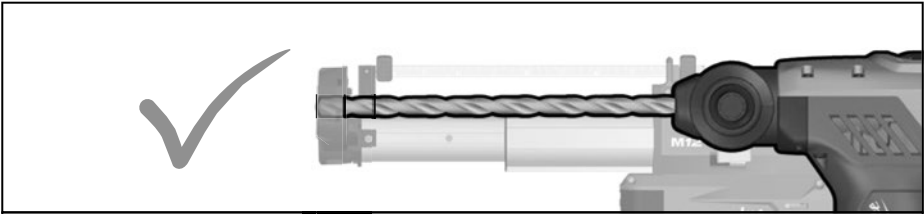
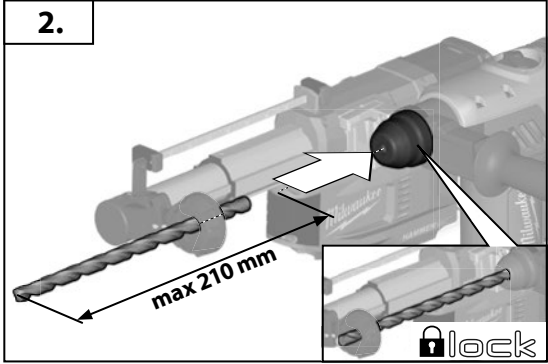
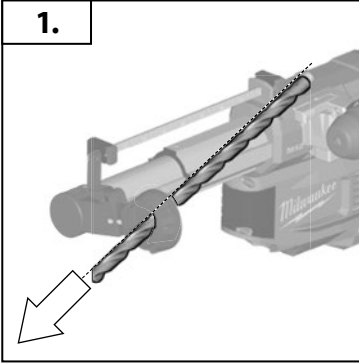

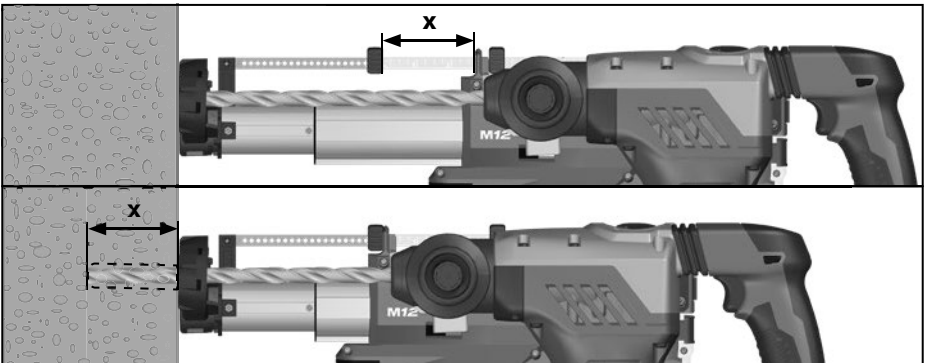
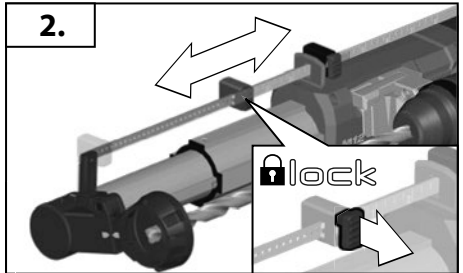
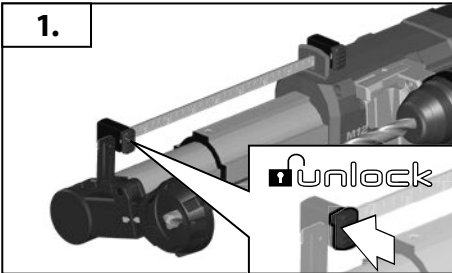
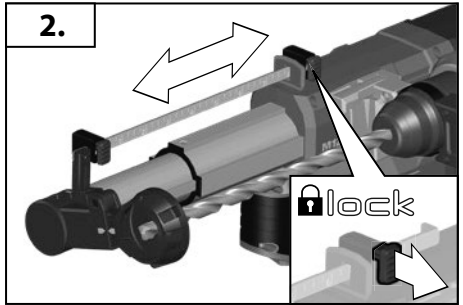
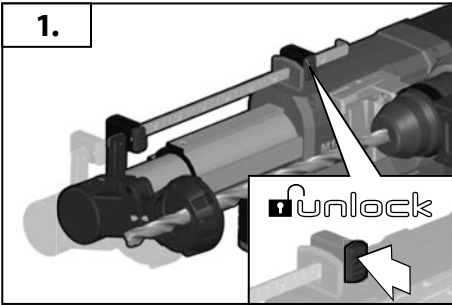
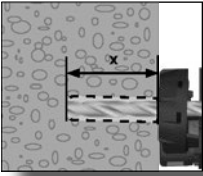



1.

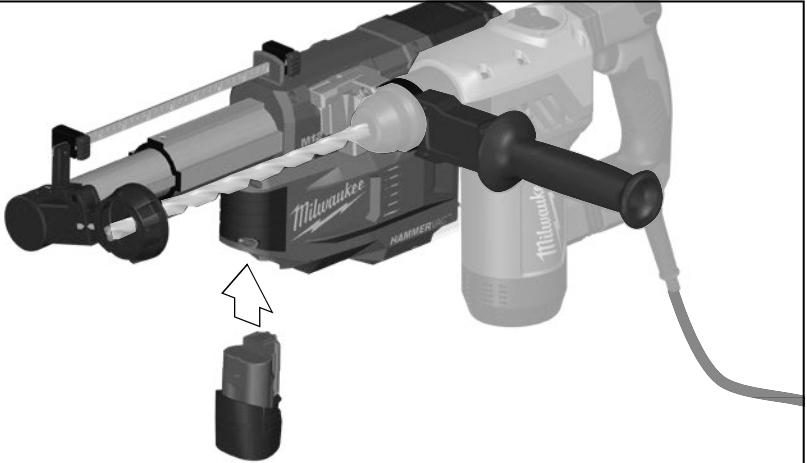

VI

2.

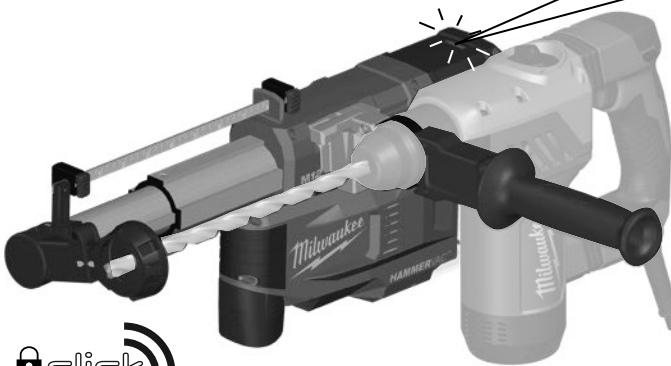

 click



2 sec



100 %

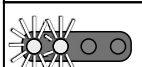

75 %



50 %

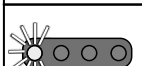

25 %

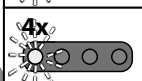

4x
<10 %



1.

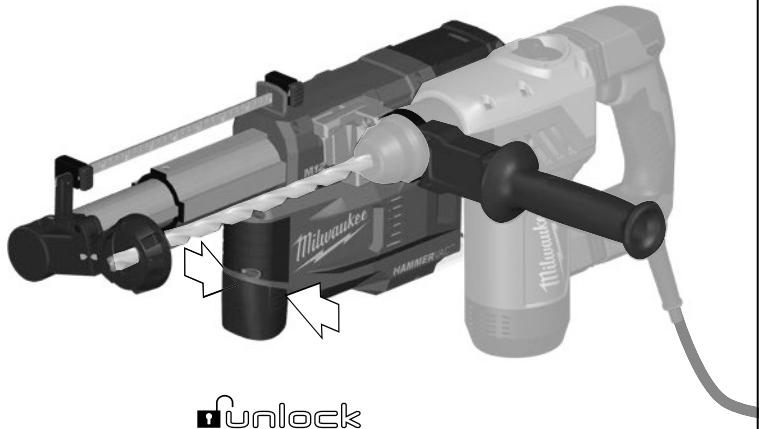

unlock



VI

2.

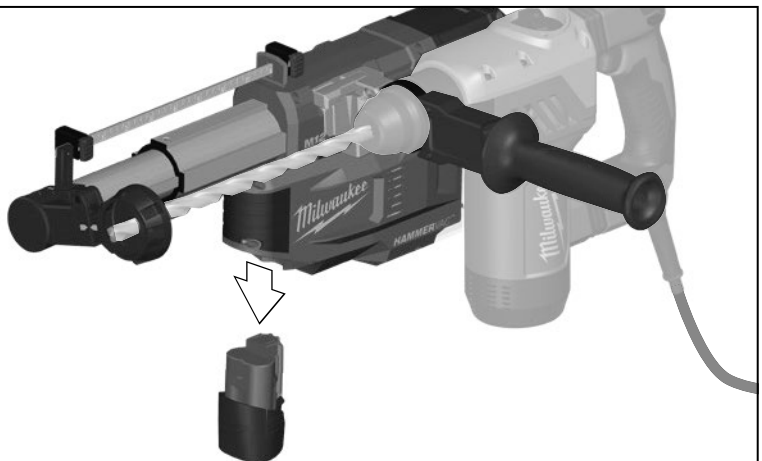

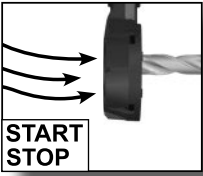

START STOP
III

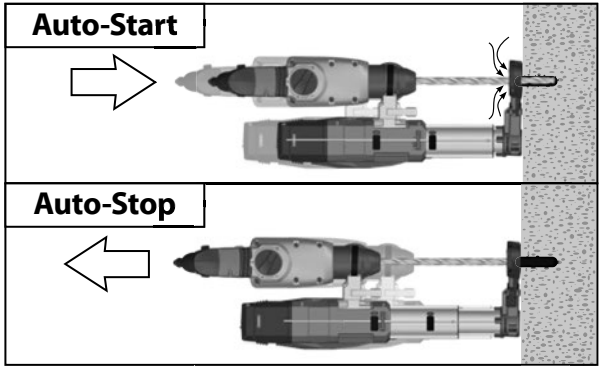
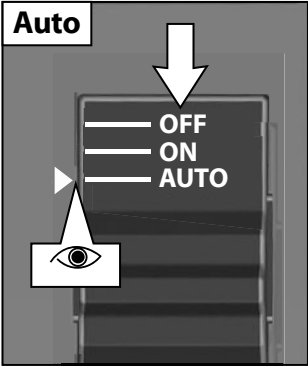
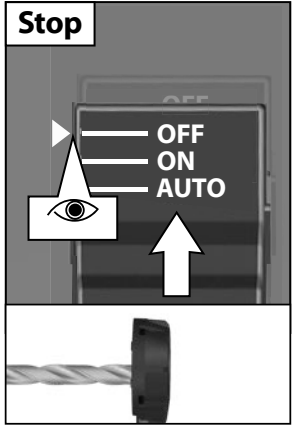
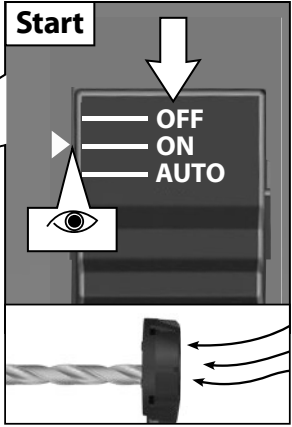
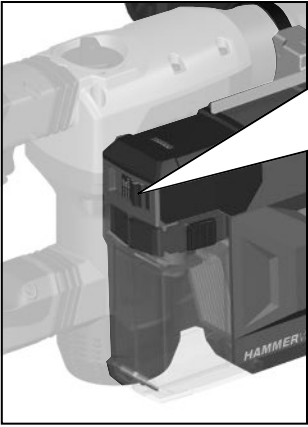
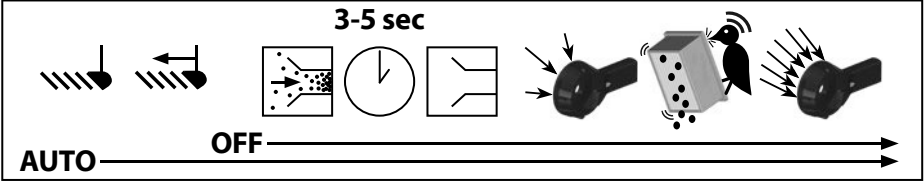

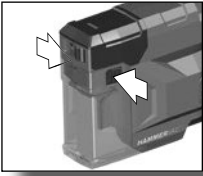

~1500 x

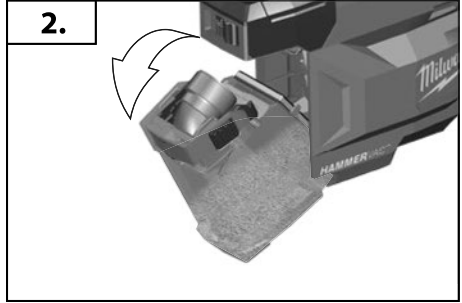
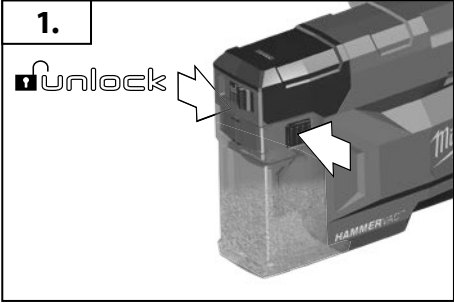
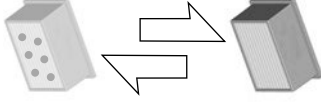

VIII

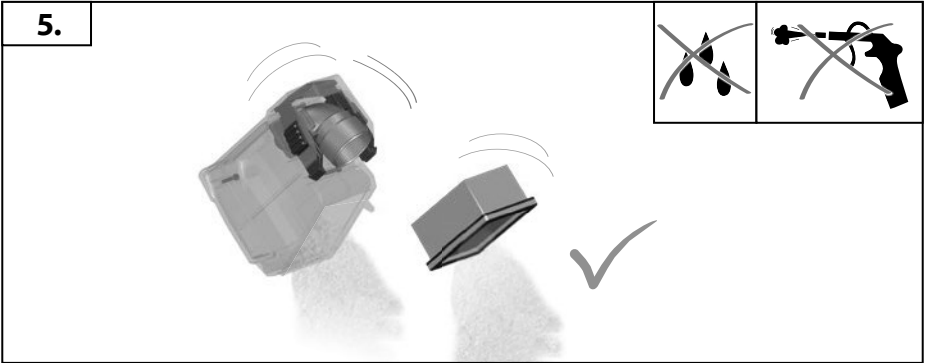
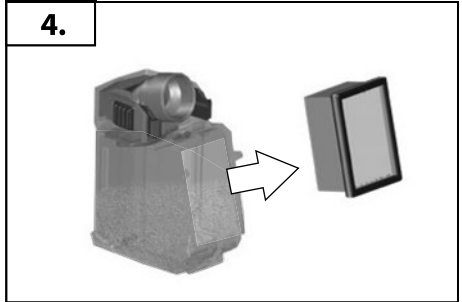
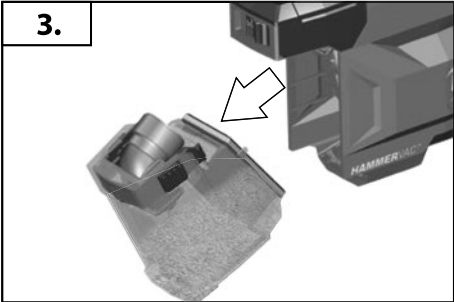

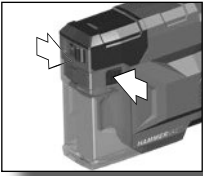

6.

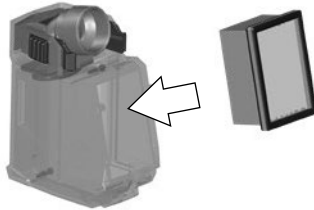

7.



8.

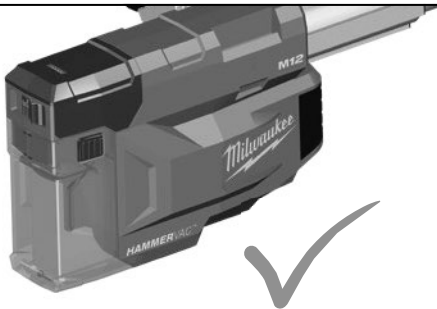



AS2-250 ELCP	4931 4472 95

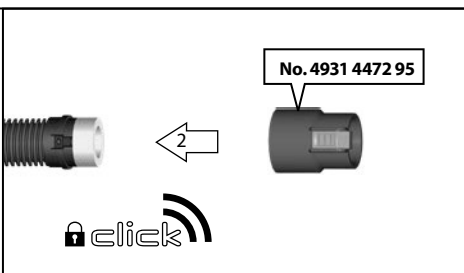
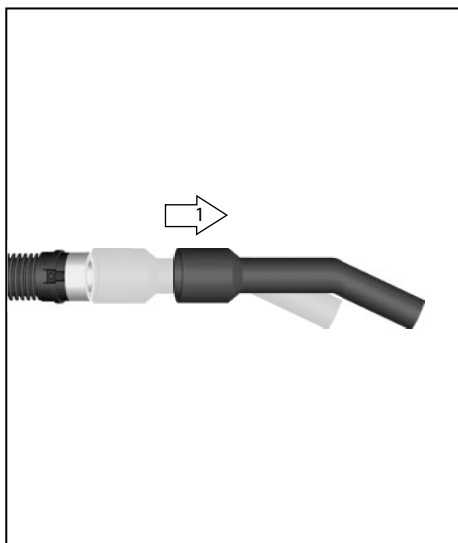
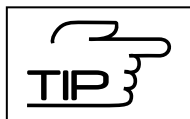

VIII

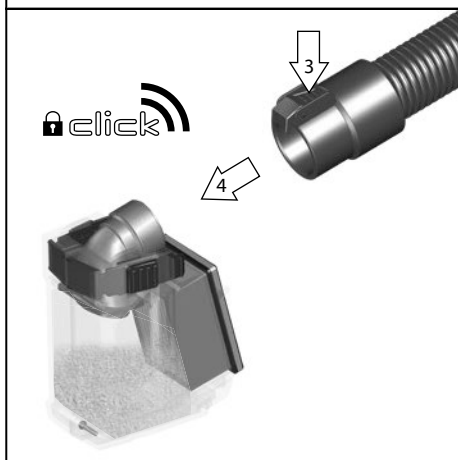
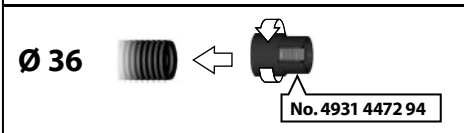
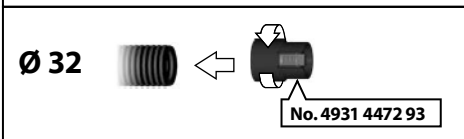

TECHNICAL DATA Dust Extractor	M12 UDEL
Production code	4748 70 02... ... 000001-999999
Battery voltage	12 V
Rated current	6,0 A
Rated Power Input	72 W
Safety class	3
Air flow rate	466 l/min 28 m ³ /h
Vacuum	2,34 kPa 23,4 hPa
Capacity	0,31 l
Filter type	HEPA H13
Filter Capacity	1500 boreholes
Collar sizes diameter	41 mm - 61 mm
Stroke max.	203 mm
Weight without battery	2 kg
Weight according EPTA-Procedure 01/2014 (Li-Ion 2,0 Ah...6,0 Ah)	2,2 kg...2,5 kg
Drilling capacity max.	ø 16 mm / ø 30 mm
Drill bit length max.	210 mm
Drilling depth max.	203 mm
Recommended Ambient Operating Temperature	-18°C ... +50°C
Recommended battery types	M12B...
Recommended charger	C12C M12C4, M12-18...
Noise information Measured values determined according to ISO 4871. Typically, the A-weighted noise levels of the tool are: Sound pressure level LpA (Uncertainty K=2dB(A)) Sound power level LWA (Uncertainty K=2dB(A))	74,5 dB(A) 86,5 dB (A)
Wear ear protectors.	
Vibration information according to EN 60335-2-69 Total vibration values (vector sum in the three axes) determined according to ISO 5349. Vibration emission value a _n Uncertainty K=	0,2 m/s ² 0,5 m/s ²



IX

⚠ WARNING! Read all safety warnings and all instructions. Failure to follow the warnings and instructions may result in electric shock, fire and/or serious injury. **Save all warnings and instructions for future reference.**

It is also essential that you read and follow the user manual for the hammer drill you use.

⚠ SAFETY INSTRUCTIONS FOR DUST EXTRACTORS

This machine is not intended for use by persons (including children) with reduced physical, sensory or mental capabilities, or lack of experience and knowledge. Children should be supervised to ensure that they do not play with the appliance.

Wear ear protectors. Exposure to noise can cause hearing loss.

The appliance must:

- only be used by persons, who have been instructed in its correct usage and explicitly commissioned with the task of operating it

Switch off the appliance and disconnect the battery in the following situations:

- Prior to cleaning and servicing
- Prior to replacing components
- Prior to changing over the appliance

English

Before starting work, the operating staff must be informed and trained within:

- use of the machine
- risks associated with the material to be picked up
- safe disposal of the picked up material

Purpose and intended use

CAUTION: This machine is for indoor use only.

CAUTION: This machine shall be stored indoors only.

This mobile dust extractor is designed, developed and rigorously tested to function efficiently and safely when properly maintained and used in accordance with the following instructions.

This machine is intended for commercial use, for example in hotels, schools, hospitals, factories, shops, offices and rental businesses.

This machine is also suitable for industrial use, such as e.g. plants, construction sites and workshops.

Accidents due to misuse can only be prevented by those using the machine.

READ AND FOLLOW ALL SAFETY INSTRUCTIONS.

Any other use is considered as improper use. The manufacturer accepts no liability for any damage resulting from such use. The risk for such use is borne solely by the user. Proper use also includes proper operation, servicing and repairs as specified by the manufacturer.

Use protective equipment. Always wear safety glasses when working with the machine. The use of protective clothing is recommended, such as dust mask, protective gloves, sturdy non-slip footwear, helmet and ear defenders.

Additional Safety and Working Instructions

Do not use the dust extractor for drilling work in wood, steel or plastic.

Do not use machines on any material containing asbestos.

The following materials should not be picked up by the vacuum cleaner

hazardous dust

flammable, explosive dust (e.g. magnesium or aluminium dust, etc.)

Do not pick up wet material. Do not use water to settle dust.

Do not use to pick up flammable or combustible liquids such as gasoline or use in areas where they may be present.

Do not pick up anything that is burning or smoking such as cigarettes, matches, or hot ashes.

Do not pick up soot, cement, plaster or drywall dust without filter in place. These are very fine particles that may affect the performance of the motor or be exhausted back into the air.

Despite using the dust extractor, a small amount of dust may still escape.

The dust produced when using this tool may be harmful to health. Do not inhale the dust. Use a dust absorption system and wear a suitable dust protection mask. Remove deposited dust thoroughly, e.g. with a vacuum cleaner.

Only use the appliance if it is in perfect condition.

Always use side handle assembly with the correct neck diameter for the rotary hammer/hammer drill. An ill-fitting side handle will not tighten securely, causing loss of control.

Never use the dust extractor without a filter, or if the filter is damaged.

This product is suitable for collection of silica dust when used in accordance with these instructions. To reduce the risk of health hazards from other vapors or dust, do not vacuum carcinogenic, toxic or hazardous materials such as asbestos, arsenic, barium, beryllium, lead, pesticides or other health endangered materials.

WARNING! Some dust created by power sanding, sawing, grinding, drilling, and other construction activities contains chemicals known to cause cancer, birth defects or other reproductive harm. Some examples of these chemicals are:

lead from lead-based paint

crystalline silica from bricks and cement and other masonry products, and

arsenic and chromium from chemically-treated lumber. Your risk from these exposures varies, depending on how often you do this type of work. To reduce your exposure to these chemicals: work in a well ventilated area, and work with approved safety equipment, such as those dust masks that are specially designed to filter out microscopic particles.

Use special care when emptying heavily loaded tanks.

To avoid spontaneous combustion, empty dust box after each use.

Do not leave dust extractor unattended when battery pack is installed. Remove battery pack when not in use and before servicing.

Do not put any object into openings. Do not use with any opening blocked; keep free of dust, lint, hair, and anything else that may reduce air flow.

WARNING! To reduce the risk of fire, personal injury, and product damage due to a short circuit, never immerse your tool, battery pack or charger in fluid or allow a fluid to flow inside them. Corrosive or conductive fluids, such as seawater, certain industrial chemicals, and bleach or bleach containing products, etc., Can cause a short circuit.

Never break open battery packs and chargers and store only in dry rooms. Keep dry at all times.

Use only System M12 chargers for charging System M12 battery packs. Do not use battery packs from other systems.

Never use dust extractor without dust box and HEPA filter in place. Never use water to clean dust box or HEPA filter.

SPECIFIED CONDITIONS OF USE

The dust extractor is designed for the extraction of dust in drilling applications with hammer drills in stone and concrete.

Do not use the product in any way other than those stated for intended use.

BATTERIES

If the appliance is to be stored unused for a long period, the batteries should be removed.

Exhausted batteries are to be removed from the appliance and safely disposed of.

Temperatures in excess of 50°C (122°F) reduce the performance of the battery pack. Avoid extended exposure to heat or sunshine (risk of overheating).

The contacts of chargers and battery packs must be kept clean.

For an optimum life-time, the battery packs have to be fully charged, after use. Battery packs which have not been used for some time should be recharged before use.



IX

To obtain the longest possible battery life remove the battery pack from the charger once it is fully charged.

For battery pack storage longer than 30 days: Store the battery pack where the temperature is below 27°C and away from moisture. Store the battery packs in a 30% - 50% charged condition. Every six months of storage, charge the pack as normal.

Do not dispose of used battery packs in the household refuse or by burning them. Milwaukee Distributors offer to retrieve old batteries to protect our environment.

Do not store the battery pack together with metal objects (short circuit risk).

TRANSPORTING LITHIUM BATTERIES

Lithium-ion batteries are subject to the Dangerous Goods Legislation requirements.

Transportation of those batteries has to be done in accordance with local, national and international provisions and regulations.

The user can transport the batteries by road without further requirements.

Commercial transport of Lithium-Ion batteries by third parties is subject to Dangerous Goods regulations. Transport preparation and transport are exclusively to be carried out by appropriately trained persons and the process has to be accompanied by corresponding experts.

When transporting batteries:

Ensure that battery contact terminals are protected and insulated to prevent short circuit. Ensure that battery pack is secured against movement within packaging. Do not transport batteries that are cracked or leak. Check with forwarding company for further advice

MAINTENANCE

Remove the battery pack before starting any work on the appliance.

The ventilation slots of the machine must be kept clear at all times.

The detachable parts (include dust collector) should be removed for cleaning.

Check for misalignment or binding of moving parts, breakage of parts and any other condition that may affect the dust extractor's operation. If damaged, have the dust extractor repaired before use. Many accidents are caused by poorly maintained tools.

The manufacturer, or an instructed person, shall perform a technical inspection at least annually, consisting of, for example, inspection of filters for damage, air tightness of the machine and proper function of the control mechanism.

For user servicing, the machine must be dismantled, cleaned and serviced, as far as is reasonably practicable, without causing risk to the maintenance staff and others.

Suitable precautions include decontamination before dismantling, provision for local filtered exhaust ventilation where the machine is dismantled, cleaning of the maintenance area and suitable personal protection.

When carrying out service or repair operations, all contaminated items which cannot be satisfactorily cleaned are to be disposed of; such items shall be disposed of in impervious bags in accordance with any current regulation for the disposal of such waste.

EC-DECLARATION OF CONFORMITY

We declare under our sole responsibility that the product described under "Technical Data" fulfills all the relevant provisions of the directives

2011/65/EU (RoHS)

2006/42/EC

2014/30/EU

and the following harmonized standards have been used.

EN 60335-1: 2012+AC:2014+A11:2014+A13:2017

+A1:2019+A2:2019+A14:2019

BS EN 60335-2-69:2012

EN 62233:2008

BS EN 55014-1:2017+A11:2020+A11:2020

BS EN 55014-2:2015

BS EN IEC 63000:2018



Winnenden, 2020-11-09

Alexander Krug / Managing Director
Authorized to compile the technical file

Techtronic Industries GmbH

Max-Eyth-Straße 10, 71364 Winnenden, Germany

GB-DECLARATION OF CONFORMITY

We declare as the manufacturer under our sole responsibility that the product described under "Technical Data" fulfills all the relevant provisions of the following Regulations

S.I. 2012/3032 (as amended), S.I. 2008/1597 (as amended),

S.I. 2016/1091 (as amended) and that the following designated standards have been used:

BS EN 60335-1: 2012+A13:2017

BS EN 60335-2-69:2012

BS EN 62233:2009

BS EN 55014-1:2017+A11:2020

BS EN 55014-2:2015

BS EN IEC 63000:2018

Winnenden, 2020-11-09

Alexander Krug / Managing Director
Authorized to compile the technical file

Techtronic Industries GmbH

Max-Eyth-Straße 10, 71364 Winnenden, Germany

SYMBOLS



Please read the instructions carefully before starting the machine.



Always wear goggles when using the machine.



Wear a suitable dust protection mask.



Safety class III



CAUTION! WARNING! DANGER!



Never expose tool to rain.



Remove the battery pack before starting any work on the appliance.



Available as an accessory.



Powertool - Not included in standard equipment, available as a tool.



Voltage



Direct Current



Do not dispose electric tools, batteries/rechargeable batteries together with household waste material. Electric tools and batteries that have reached the end of their life must be collected separately and returned to an environmentally compatible recycling facility. Check with your local authority or retailer for recycling advice and collection point.



European Conformity Mark



British Conformity Mark



Ukraine Conformity Mark



EurAsian Conformity Mark



Copyright 2020
Techtronic Industries GmbH
Max-Eyth-Straße 10
71364 Winnenden
Germany
+49 (0) 7195-12-0
www.milwaukeeetool.eu

Techtronic Industries (UK) Ltd
Fieldhouse Lane
Marlow Bucks SL7 1HZ
UK



**EAC UK
CA**

(11.20)

4100 4259 64