

ENGINE TOOL PARTS LIST

ENGINE CHAIN SAW Model CS 40EA

2010-8-18
(E1)

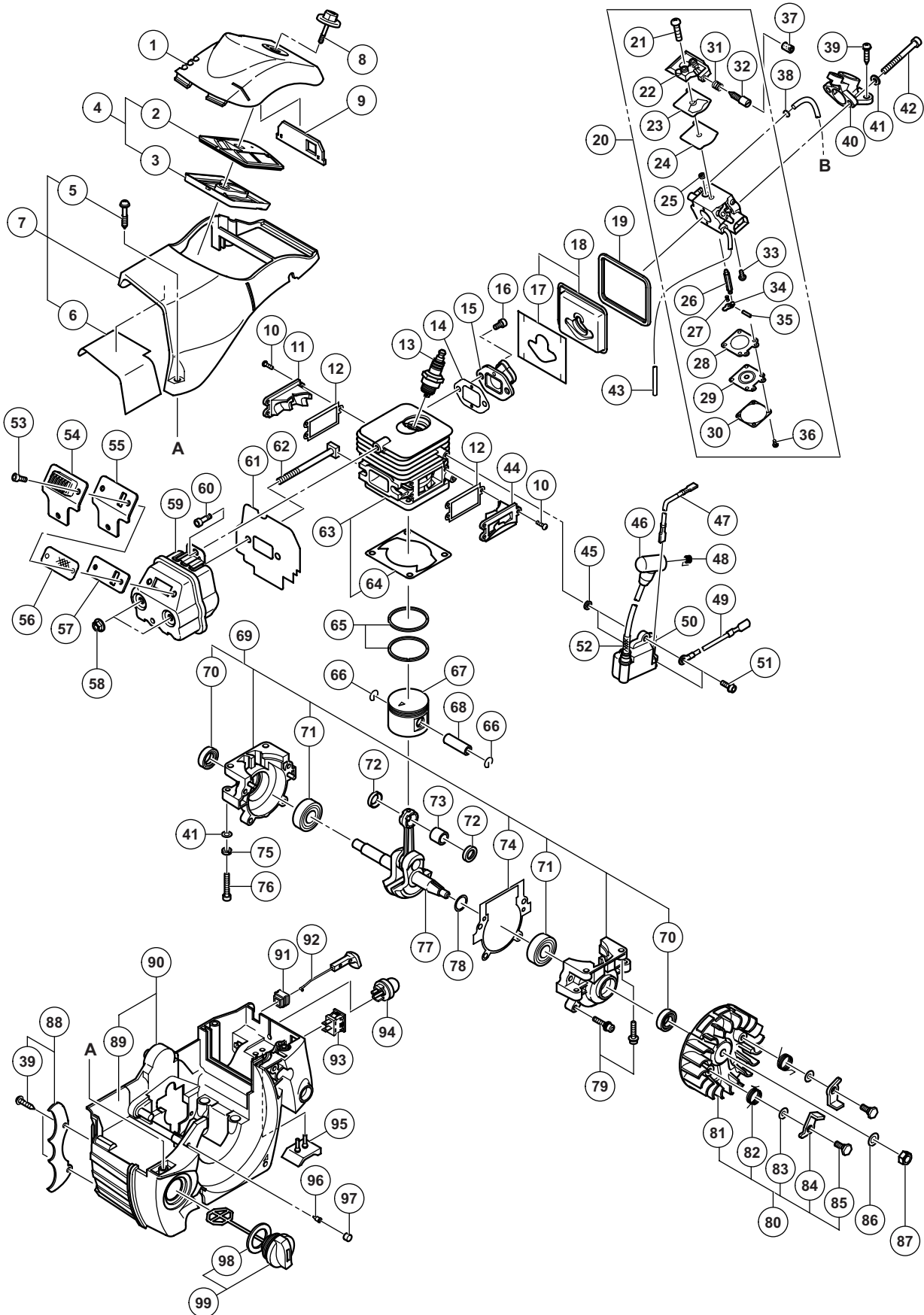

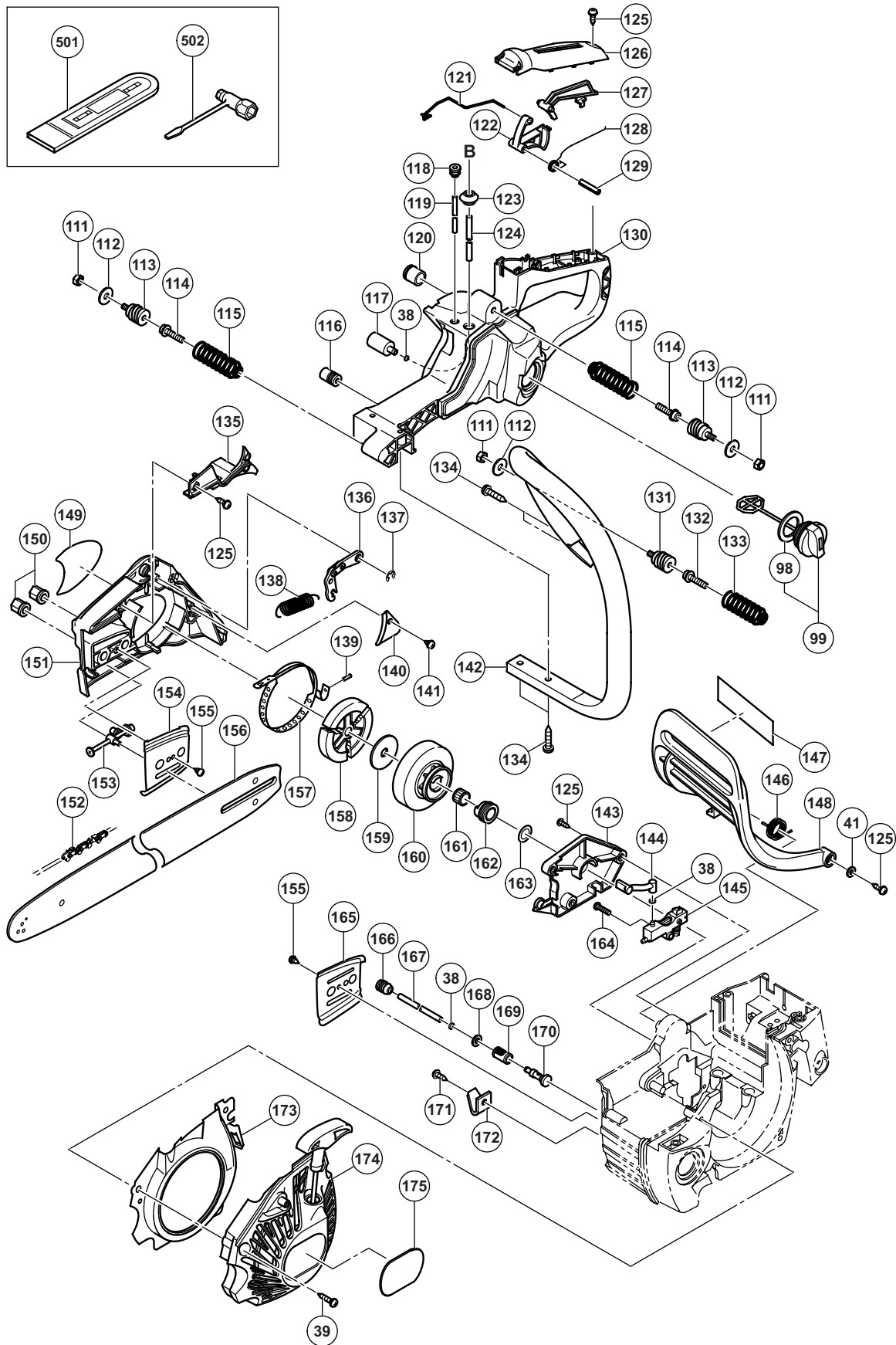

PARTS

CS 40EA

ITEM NO.	CODE NO.	DESCRIPTION	NO. USED	REMARKS
1	669-8424	CLEANER COVER	1	
2	669-6908	CLEANER ELEMENT (B)	1	
3	669-6907	CLEANER ELEMENT (A)	1	
4	669-6891	CLEANER ELEMENT ASS'Y	1	INCLUD. 2, 3
5	669-6903	COVER SET BOLT	3	
6	669-8520	ALUMINUM TAPE (A)	1	
* 7	669-8462	CYLINDER COVER ASS'Y	1	INCLUD. 5, 6
* 7	669-8519	CYLINDER COVER ASS'Y	1	INCLUD. 5, 6 FOR EUROPE, USA, CAN
* 8	669-8425	CLEANER KNOB (VERMILION)	1	
* 8	669-8438	CLEANER KNOB (GREEN)	1	FOR USA, CAN
9	669-6904	SHUTTER PLATE	1	
10	949-216	MACHINE SCREW M4 X 10 (10 PCS.)	6	
11	669-8407	SCAVENGING COVER (B)	1	
12	669-6852	COVER PACKING	2	
* 13	668-5782	SPARK PLUG BPMR7A	1	
* 13	669-8432	SPARK PLUG BPM-7A	1	
14	669-6895	INTAKE PACKING	1	
15	669-8419	INTAKE	1	
16	949-765	HEX. SOCKET HD. BOLT M5 X 12 (10 PCS.)	2	
17	669-8524	ALUMINUM TAPE (B)	1	
18	669-8461	CARBURETOR INSULATOR ASS'Y	1	INCLUD. 17
19	669-6896	CARB. INSULATOR RUBBER	1	
20	669-8433	CARBURETOR ASS'Y	1	INCLUD. 21-36
21	668-5210	SCREW	1	
22		PUMP BODY	1	
23	668-5212	PUMP GASKET	1	
24	668-5213	PUMP DIAPHRAGM	1	
25	668-4700	INLET SCREEN	1	
26	668-5215	NEEDLE VALVE	1	
27	669-0873	VALVE SPRING	1	
28	668-5220	DIAPHRAGM PACKING	1	
29	668-4690	METERING DIAPHRAGM COMP.	1	
30	668-5222	DIAPHRAGM COVER	1	
31	669-0766	IDLE ADJUST SPRING	1	
32	668-5298	IDLE ADJUST SCREW	1	
33	668-5218	HINGE PIN SET SCREW	1	
34	668-5217	CONTROL LEVER	1	
35	668-5219	HINGE PIN	1	
36	668-5223	SET SCREW	4	
37	668-5224	IDLE SPONGE	1	
38	668-5311	CLIP	4	
39	302-089	TAPPING SCREW (W/FLANGE) D5 X 20 (BLACK)	6	
40	669-8427	CLEANER SUPPORT	1	
41	668-5408	WASHER 5	7	
42	669-6317	HEX. SOCKET HD. BOLT M5 X 45	2	
43	669-8434	FUEL PIPE	1	
44	669-8406	SCAVENGING COVER (A)	1	
45	668-4600	WASHER	2	
46	669-8435	PLUG CAP	1	
47	668-5365	CORD (A)	1	

PARTS

CS 40EA

ITEM NO.	CODE NO.	DESCRIPTION	NO. USED	REMARKS
48	669-8436	METAL FITTING OF PLUG CAP	1	
49	668-5338	CORD (B)	1	
50	669-8416	IGNITION COIL	1	
51	669-6326	HEX. SOCKET HD. BOLT (W/FLANGE) M4 X 18	2	
52	669-8457	CORD INSULATION TUBE	1	
53	669-8442	HEX. SOCKET BOLT(SUS) M4	3	
54	669-8458	MUFFLER PROTECTOR	1	
55	669-8459	MUFFLER PROTECTOR PACKING	1	
56	669-6874	MUFFLER GAUZE	1	
57	669-8460	EXHAUST PLATE	1	
58	329-934	FLANGE NUT M6	2	
* 59	669-8410	MUFFLER	1	FOR EUROPE, USA, CAN, JPN
* 59	669-8411	MUFFLER	1	
60	305-574	HEX. SOCKET HD. BOLT (W/SP.WASHER) M5 X 16	1	
61	669-8412	MUFFLER PACKING	1	
62	669-8437	SQUARE HEAD BOLT M6	2	
63	669-8430	CYLINDER ASS'Y	1	INCLUD. 64
64	669-6864	CYLINDER PACKING	1	
65	669-6858	PISTON RING	2	
66	669-6854	CIR CLIP	2	
67	669-8521	PISTON (M)	1	
68	669-6855	PISTON PIN	1	
69	669-8441	CRANK CASE SET	1	INCLUD. 70, 71, 74
70	668-4607	OIL SEAL TB 12227	2	
71	668-5328	BALL BEARING	2	
72	669-6856	PISTON PIN COLLAR	2	
73	669-8445	NEEDLE BEARING (A)	1	
74	669-6863	CRANK CASE PACKING	1	
75	949-454	SPRING WASHER M5 (10 PCS.)	4	
76	668-5412	SEAL LOCK HEX. SOCKET HD. BOLT M5	4	
77	669-6853	CRANK SHAFT	1	
* 78	669-6865	SHIM	1	T 0.2
* 78	669-6866	SHIM	1	T 0.3
* 78	669-6867	SHIM	1	T 0.4
79	305-583	HEX. SOCKET HD. BOLT (W/SP.WASHER) M5 X 20	8	
80	669-8414	MAGNETO SUB ASS'Y	1	INCLUD. 81-85
81	669-8415	MAGNETO ROTOR	1	
82	669-8417	STARTER PAWL SPRING	2	
83	669-6857	WASHER 0.8	2	
84	669-6877	STARTER PAWL	2	
85	669-6878	STEP BOLT	2	
86	669-6880	BOLT WASHER D7	1	
87	669-6879	FLYWHEEL NUT	1	
88	669-6329	SPIKE SET	1	INCLUD. 39
89	669-8523	ALUMINUM TAPE	1	
90	669-8448	ENGINE CASE SUB	1	
91	668-5369	CHOKE ROD RUBBER	1	
* 92	669-8463	CHOKE BOTTON	1	
* 92	669-8464	CHOKE BOTTON	1	FOR USA, CAN
93	668-5364	STOP SWITCH	1	

PARTS

CS 40EA

ITEM NO.	CODE NO.	DESCRIPTION	NO. USED	REMARKS
94	668-5139	PRIMING PUMP COMP.	1	
95	669-6870	REAR DAMPER	1	
96	668-5370	AIR VENT VALVE (B)	1	
97	668-5371	AIR VENT SPONGE	1	
98	668-5386	TANK CAP PACKING	2	
*	99	668-5384	FUEL TANK CAP ASS'Y	2 INCLUD. 98
*	99	668-5385	FUEL TANK CAP ASS'Y (GREEN)	2 FOR USA, CAN
111	669-8449	NUT M6	3	
112	949-432	BOLT WASHER M6 (10 PCS.)	3	
113	669-8409	SPRING HOLDER	2	
114	669-6872	FLANGED TAPPING SCREW D6	2	
115	669-8408	ANTIVIBRATION SPRING	2	
116	669-6873	FRONT DAMPER	1	
117	668-5199	PUMP FILTER BODY	1	
118	669-6970	RETURN GROMMET	1	
119	669-8401	FUEL PIPE (PINK)	1	
120	668-5351	INNER CAP	1	
121	669-8420	THROTTLE ROD	1	
*	122	669-8451	THROTTLE LEVER (VERMILION)	1
*	122	669-8452	THROTTLE LEVER (GREEN)	1 FOR USA, CAN
123	668-5308	FUEL GROMMET(A)	1	
124	669-8522	FUEL PIPE	1	
125	305-812	TAPPING SCREW (W/FLANGE) D4 X 16 (BLACK)	8	
126	668-5367	REAR HANDLE GRIP	1	
*	127	668-5350	TRIGGER LOCKOUT (VERMILION)	1
*	127	668-5420	TRIGGER LOCKOUT (GREEN)	1 FOR USA, CAN
128	668-5349	THROTTLE LEVER SPRING	1	
129	668-5282	SPRING PIN 5 X 25	1	
130	669-6871	REAR HANDLE	1	
131	669-8429	SPRING HOLDER	1	
132	881-722	HEX. SOCKET HD. BOLT (W/FLANGE) M6 X 20	1	
133	669-8428	ANTIVIBRATION SPRING	1	
134	305-558	TAPPING SCREW (W/FLANGE) D5 X 25 (BLACK)	4	
135	669-6901	BRAKE LINK COVER	1	
136	668-5388	BRAKE LINK	1	
137	955-479	RETAINING RING (E-TYPE) FOR D6 SHAFT	1	
138	669-6900	BRAKE SPRING	1	
139	668-5391	NEEDLE ROLLER D3	1	
140	669-6899	BRAKE BAND PLATE	1	
141	311-945	TAPPING SCREW (W/FLANGE) D4 X 10 (BLACK)	1	
142	669-8426	FRONT HANDLE	1	
143	669-6893	OIL PUMP COVER	1	
144	669-6892	OIL PIPE	1	
145	669-6887	OIL PUMP	1	
146	668-5374	BRAKE LEVER SPRING	1	
147		CAUTION LABEL	1	
148	668-5373	BRAKE HANDLE	1	
149		NAME PLATE	1	
150	668-5416	CHAIN BAR CLAMP NUT	2	
*	151	669-8422	SIDE CASE SUB (VERMILION)	1

PARTS

CS 40EA

ITEM NO.	CODE NO.	DESCRIPTION	NO. USED	REMARKS	
*	151	669-8454	SIDE CASE SUB (GREEN)	1	FOR USA, CAN
*	152	668-7270	SAW CHAIN 13 INCH	1	
*	152	668-7335	SAW CHAIN 15 INCH	1	
*	152	668-7296	SAW CHAIN 16 INCH	1	
*	152	668-7284	SAW CHAIN 18 INCH	1	
	153	668-5393	CHAIN PULLER	1	
	154	669-6902	GUIDE PLATE (B)	1	
	155	668-5415	TAPPING SCREW D3 X 8	2	
*	156	669-6911	CHAIN BAR 13 INCH	1	
*	156	669-6912	CHAIN BAR 15 INCH	1	
*	156	669-6983	CHAIN BAR 16 INCH	1	
*	156	669-6982	CHAIN BAR 18 INCH	1	
	157	669-8423	BRAKE BAND	1	
	158	669-6883	CLUTCH	1	
	159	669-6882	CLUTCH WASHER (B)	1	
	160	669-6881	CLUTCH HOUSING	1	
	161	669-6884	NEEDLE BEARING	1	
	162	669-6886	WORM	1	
	163	669-6885	WASHER	1	
	164	949-219	MACHINE SCREW M4 X 16 (10 PCS.)	1	
	165	669-6898	GUIDE PLATE (A)	1	
	166	669-6868	OIL GROMMET (A)	1	
	167	669-8453	FUEL PIPE	1	
	168	668-5407	BOLT WASHER D5	1	
	169	669-8455	OIL FILTER	1	
	170	669-6869	OIL FILTER BODY	1	
	171	669-8456	FLANGED TAPPING SCREW D5 X 15	1	
	172	669-6894	CHAIN CATCHER	1	
	173	669-6906	AIR DEFLECTOR	1	
*	174	669-8421	RECOIL STARTER (VERMILION)	1	
*	174	669-8431	RECOIL STARTER (GREEN)	1	FOR USA, CAN
	175		HITACHI LABEL	1	

STANDARD ACCESSORIES

ITEM NO.	CODE NO.	DESCRIPTION	NO. USED	REMARKS	
*	501	668-5439	CHAIN COVER	1	13 INCH
*	501	669-6909	CHAIN COVER	1	15,16 INCH
*	501	669-6910	CHAIN COVER	1	18 INCH
	502	668-5402	COMBI BOX SPANNER 10/19MM	1	