

Light control function

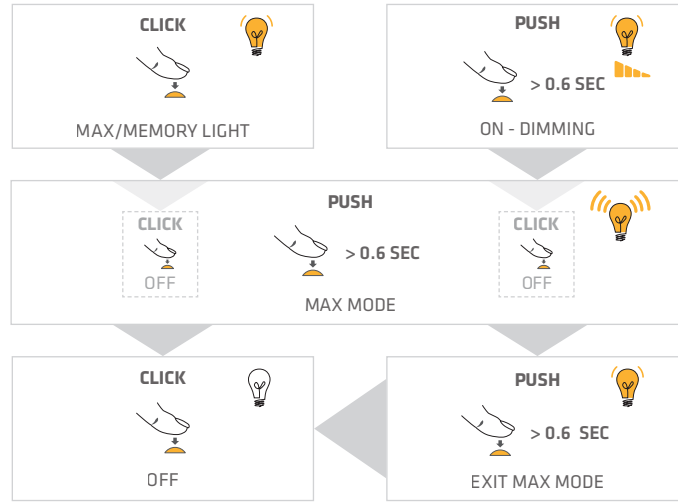

Changing Battery

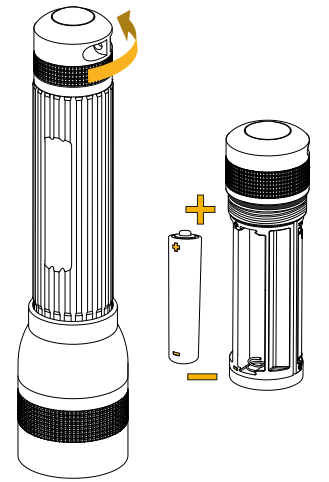

Additional online information



This manual may contain typographical errors. Data and information are subject to change without notice

Steiner A/S
Dysse 3
DK-8200 Aarhus N
Phone: +45 87 52 52 12
Fax: +45 87 52 52 15
info@suprabeam.com
www.suprabeam.com

Hyperfocu

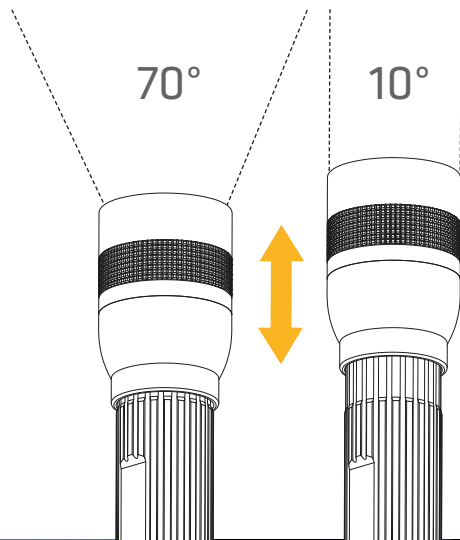

Specifications



Warning



For the technician in demanding work situations, it is essential with the best gear available. The Q1 provides remarkable power and comes in a convenient size for your pocket.

A PURE SUPRABEAM CLASSIC...

- POWERFUL PEN TORCH
- ROTATING HYPERFOCUS
- SMALL AND RELIABLE



Q1

- 2xAAA
- 70 m
- 10° - 70°
- 56 g

