

# Product leaflet

**Product**  
Compressed air filter

**Model No.**  
SR 99-1

**Ordering No.**  
H03-2812

## Product Description

The SR 99-1 compressed air filter is used for producing clean breathing air from ordinary compressed air. The unit consists of a regulator (C), pre-collector (D) and main filter (SR 292), all of which are mounted in an enclosing steel sheet stand. The unit can be placed on the floor or mounted on a wall. The pre-separator has automatic drainage, separates coarser particles, water and oil. The SR 292 main filter consists of a carbon filter part (500g), surrounded by two P3 particulate filters. The air is cleaned to remove any remaining particles/gases/vapours/odours. A Y coupling that increases the number of outlets is available as accessory.

## Technical specification

SR 99-1	
Inlet connection	1/2" BSP
Inlet pressure	6–10 bar
Outlet connections	One safety coupling and one plugged opening
Air flow	Maximum 900 l/min - three users
Filter area P3	≈ 2200 cm <sup>2</sup>
Activated carbon	≈ 500 grams
Adsorption capacity	≈ 100–150 grams oil.

- A. Pressure gauge
- B. Inlet
- C. Regulating valve
- D. Pre-collector
- E. Drain
- F. Outlet
- G. Particle filter
- H. Activated carbon

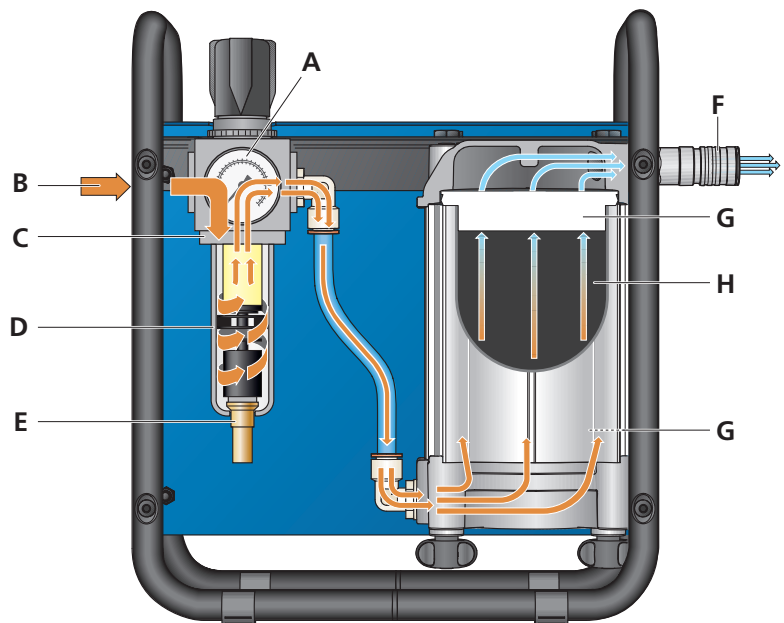

**Head Office**  
Tel: +46 10 484 87 00

Visiting address:  
Stockholmsvägen 33  
SE-181 33 Lidingö

**Factory**  
Tel: +46 10 484 87 00

Visiting address:  
Västergatan 4  
SE-341 50 Lagan

**Sundström**  
www.srsafety.com