

FLUKE®

56x

*Infrared
Thermometers*

Getting Started

PN 3833028

December 2010

©2010 Fluke Corporation. All rights reserved. Printed in China.

Specifications are subject to change without notice.

All product names are trademarks of their respective companies.

LIMITED WARRANTY AND LIMITATION OF LIABILITY

This Fluke product will be free from defects in material and workmanship for two years from the date of purchase. This warranty does not cover fuses, disposable batteries, or damage from accident, neglect, misuse, alteration, contamination, or abnormal conditions of operation or handling. Resellers are not authorized to extend any other warranty on Fluke's behalf. To obtain service during the warranty period, contact your nearest Fluke authorized service center to obtain return authorization information, then send the product to that Service Center with a description of the problem.

THIS WARRANTY IS YOUR ONLY REMEDY. NO OTHER WARRANTIES, SUCH AS FITNESS FOR A PARTICULAR PURPOSE, ARE EXPRESSED OR IMPLIED. FLUKE IS NOT LIABLE FOR ANY SPECIAL, INDIRECT, INCIDENTAL OR CONSEQUENTIAL DAMAGES OR LOSSES, ARISING FROM ANY CAUSE OR THEORY. Since some states or countries do not allow the exclusion or limitation of an implied warranty or of incidental or consequential damages, this limitation of liability may not apply to you.

Fluke Corporation
P.O. Box 9090
Everett, WA 98206-9090
U.S.A.
11/99

Fluke Europe B.V.
P.O. Box 1186
5602 BD Eindhoven
The Netherlands

Table of Contents

Title	Page
Introduction.....	1
Safety Information	1
Using the Thermometer.....	5
Changing Batteries.....	5
Cable Connections (568 Only)	6
561 Display.....	6
566/568 Menu Overview	8
Specifications Summary.....	10

56x

Infrared Thermometers

Infrared Thermometers

Introduction

The 561, 566 and 568 Infrared Thermometers (“the Thermometers” or “the Product”) are for non-contact temperature measurement. These Thermometers determine an object’s surface temperature by measuring the amount of infrared energy radiated by the object’s surface. The Thermometers also support contact-temperature measurement via K-type thermocouple.

Note that the Japanese models indicate Celsius only.

Safety Information

A **Warning** identifies conditions and actions that pose hazard(s) to the user; A **Caution** identifies conditions and procedures that could cause Product damage, equipment under test damage, or permanent loss of data.

Symbols used on the Product and in this manual are explained in Table 1 and Figures 1 and 2.

  Warning

To prevent eye damage and personal injury:

- **Read all safety Information before you use the Product.**
- **Do not look directly into the laser with optical tools (for example, binoculars, telescopes, microscopes). Optical tools can focus the laser and be dangerous to the eye.**
- **Do not look into the laser. Do not point laser directly at persons or animals or indirectly off reflective surfaces.**
- **Do not use laser viewing glasses as laser protection glasses. Laser viewing glasses are used only for better visibility of the laser in bright light.**
- **Do not open the Product. The laser beam is dangerous to eyes. Have the Product repaired only through an approved technical site.**
- **Replace the batteries when the low battery indicator shows to prevent incorrect measurements.**
- **The battery door must be closed and locked before you operate the Product.**
- **Do not use the Product if it operates incorrectly.**
- **Do not use the Product around explosive gas, vapor, or in damp or wet environments.**

- **Do not connect the optional external probe to live electrical circuits.**
- **See emissivity information for actual temperatures. Reflective objects result in lower than actual temperature measurements. These objects pose a burn hazard.**
- **Do not leave the Product on or near objects of high temperature.**
- **Use of controls or adjustments or performance of procedures other than those specified herein may result in hazardous laser radiation exposure.**
- **Use the Product only as specified, or the protection supplied by the Product can be compromised.**

⚠ Caution

To avoid damaging the Product or the equipment under test, protect them from the following:

- **EMF (electro-magnetic fields) from arc welders, induction heaters, etc.**
- **Static electricity**
- **Thermal shock (caused by large or abrupt ambient temperature changes- for highest accuracy, allow 30 minutes for Product to stabilize before use).**

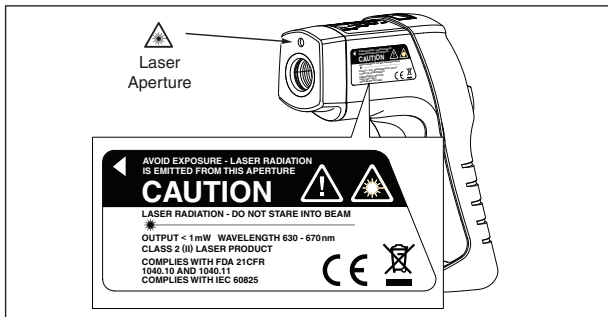

Figure 1. 561 Laser Safety Markings

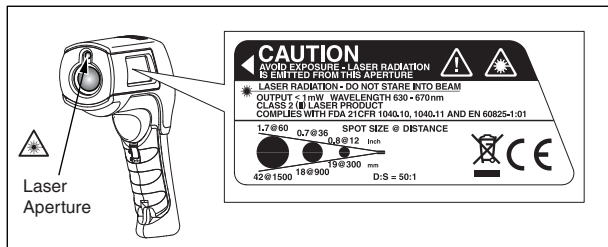

Figure 2. 566/568 Laser Safety Markings

Using the Thermometer

To take a temperature reading, point the Thermometer at the desired object and pull the trigger. You can use the laser pointer to help aim the Thermometer. You may also insert the K-type thermocouple probe for contact measurement.

Changing Batteries

To change the batteries, see Figure 3.

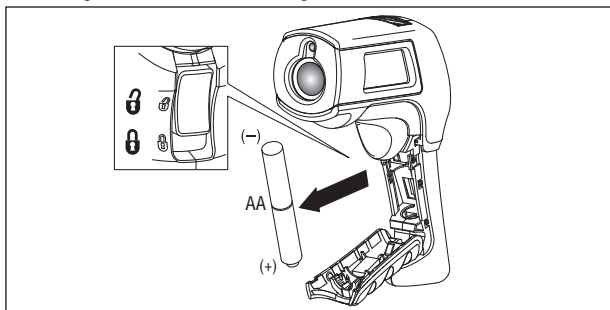
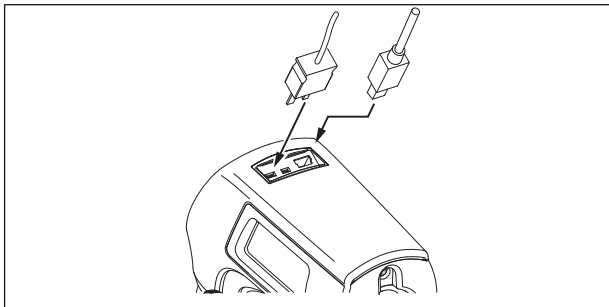

Figure 3. Changing Batteries (566/568 is shown)

Cable Connections (568 Only)

To connect the USB and Thermocouple to the 568, see Figure 4.



ewm05.eps

Figure 4. Connecting the K-Type Thermocouple, USB Cable (568 Only)

Note

To prevent incorrect readings, do not perform a temperature measurement of an earthed conductor while the 568 is connected to a PC that is earthed by a three-phase grounding plug.

561 Display

The primary temperature display reports the current or last IR temperature read until the 7-second hold time elapses.

The secondary temperature display reports current thermocouple temperature when a type-K thermocouple is attached. See Figure 5.

Note

When the battery is low,  appears on the display.

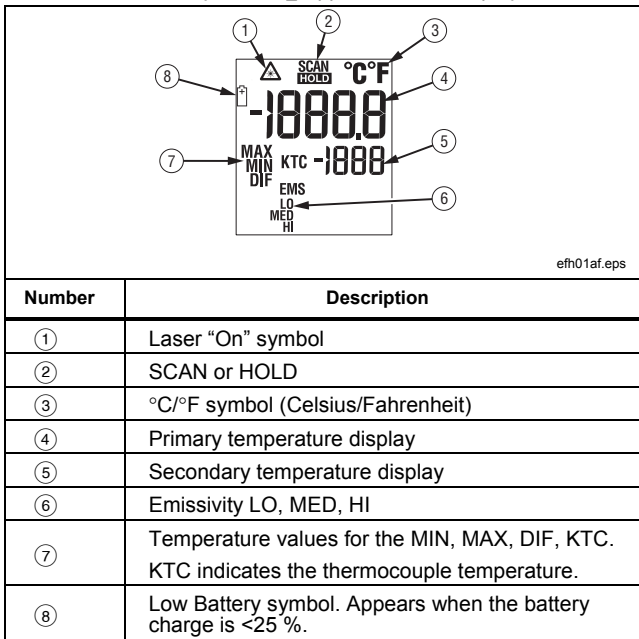
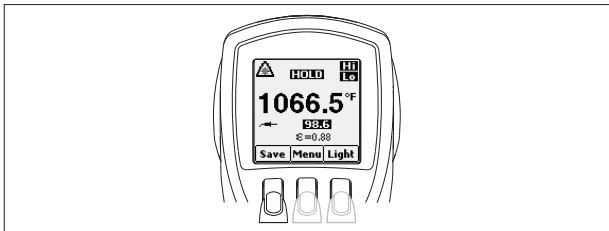

Figure 5. 561 Thermometer Display

566/568 Menu Overview

There are many settings that can be easily changed by using the menu. Table 1 is a top-level description. Selecting the **Menu** button advances the menu to the next level. Figure 6 shows the LCD and menu interface. The Users Manual explains the menus in full detail.



ewm01a.eps

Figure 6. Menu Navigation

Table 1. Top-Level Menu Description

Level	Left Softkey	Description	Center Softkey	Right Softkey	Description
1	Save	Save reading to memory	Menu	Light	Turn on bright backlight
2	Mem	Review / delete memories	Menu	ϵ	Set emissivity
3	MnMx	Enables Min/Max	Menu	Avg	Enable Avg/Diff
4	°F/°C	Toggle between C and F	Menu	Alarm	Set and enable alarms
5	 (Lock)	Lock the Thermometer on	Menu	Laser	Toggle the laser on/off
6	Setup	- Turn off backlight - Change Time/Date - Change Language	Menu		

Specifications Summary

See Users Manual on CD for full specifications.

Feature	561	566	568
IR Temperature Range	-40 °C to 550 °C (-40 °F to 1022 °F)	-40 °C to 650 °C (-40 °F to 1202 °F)	-40 °C to 800 °C (-40 °F to 1472 °F)
Accuracy	$<0\text{ °C}: \pm(1.0\text{ °C} + 0.1\text{ %}/1\text{ °C})$ $>0\text{ °C}: \pm 1\text{ %}$ or $\pm 1.0\text{ °C}$, whichever is greater $(<32\text{ °F} \pm 2\text{ °F} \pm 0.1\text{ %}/1\text{ °F})$ $>32\text{ °F}: \pm 1\text{ %}$ or $\pm 2\text{ °F}$, whichever is greater		
K-Type Thermocouple Input Temperature Range	0 °C to 100 °C (32 °F to 212 °F)	-270 °C to 1372 °C (-454 °F to 2501 °F)	
K-Type Thermocouple Input Accuracy	Input accuracy $\pm 2.2\text{ °C}$ ($\pm 4\text{ °F}$)	-270 °C to $-40\text{ °C}: \pm(1\text{ °C} + 0.2\text{ %}/1\text{ °C})$ $(-454\text{ °F}$ to $-40\text{ °F}: \pm(2\text{ °F} + 0.2\text{ %}/1\text{ °F}))$ -40 °C to $1372\text{ °C}: \pm 1\text{ %}$ or 1 °C (-40 °F to $2501\text{ °F}: \pm 1\text{ %}$ or 2 °F), whichever is greater	

Infrared Thermometers
Specifications Summary

Feature	561	566	568
Distance:Spot (90 % energy)	12:1	30:1	50:1
Laser sighting	Single laser, output <1 mW Class II, wavelength 630 to 670 nm		
Emissivity	LO, MED, HI	Digitally adjustable from 0.10 to 1.00 by 0.01 or via built-in table of common materials	
Data storage	-	20 points	99 points
Communication	none		USB 2.0
Operating Altitude	3000 meters above mean sea level		
Storage Altitude	12,000 meters above mean sea level		
Relative Humidity	10 % to 90 % RH non-condensing up to 30 °C (86 °F)		
Operating Temperature	0 °C to 50 °C (32 °F to 122 °F)	0 °C to 50 °C (32 °F to 122 °F)	
Storage Temperature	-20 °C to 65 °C (-4 °F to 149 °F)	-20 °C to 60 °C (-4 °F to 149 °F)	

56x*Getting Started*

Feature	561	566	568
Power	2 AA /LR6 Batteries (alkaline or NiCD)		2 AA /LR6 Batteries or USB connection when used with a PC
Battery Life	12 hours with laser and backlight on; 100 hours with laser and backlight off, at 100 % duty cycle (Thermometer continuously on)		

Feature	K-Type Thermocouple Probe (Bead Type)
Measurement Range	-40 °C to 260 °C (-40 °F to 500 °F)