

## 10.8V 10MM DRILL/DRIVER (NAKED) | CL3.P10JD



### Description

- Compact and lightweight design for comfort of use
- 15 Position adjustable torque control for consistent screw driving into a variety of materials with different screw sizes
- Integral LED with automatic timed switch-off
- 10 mm single sleeve keyless chuck
- Two speed settings and variable speed trigger for excellent speed control
- Protection bumpers built into the machine casing
- Compatible with any FACOM or DEWALT® 10.8V battery packs
- Power output 180W
- No load speed 0-400 / 1500
- Max hard joint torque 24Nm
- 10mm chuck
- Voltage 10.8V
- Vibration • Vibration 1.5m/s<sup>2</sup>/a
- Acoustic pressure 65dB(A)
- Acoustic power 76dB(A)
- Supplied without batteries and charger

### Information

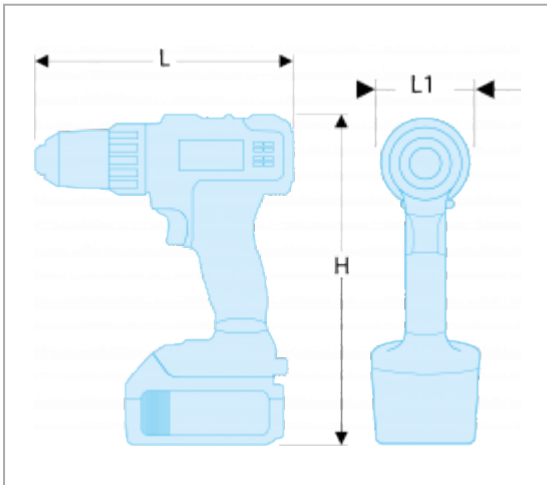

H [mm]	175
L [mm]	195
L1 [mm]	50
[g]	900