

*Manuale d'uso e manutenzione
Instruction and maintenance manual
Manuel d'utilisation et d'entretien
Betriebs- und Bedienungshandbuch
Manual de uso y mantenimiento
Instructie- en onderhoudshandleiding
Brugsanvisning brug og vedligeholdelse*



TRANSLATION OF THE ORIGINAL INSTRUCTIONS



CE

DECLARATION OF CONFORMITY

The following declaration is attached to the compressor in original copy.
All identification data: manufacturer, model, code and serial number are stamped on EC label.
For any request for copies it is ESSENTIAL to provide ALL the data stamped on EC label.

IT	Dichiara sotto la sua esclusiva responsabilità, che il compressore d'aria qui di seguito descritto è conforme a tutte le disposizioni pertinenti delle seguenti direttive comunitarie: 2006/42/CE, 2014/30/UE Sono state applicate le seguenti norme armonizzate nell'ultima versione pubblicata sulla Gazzetta Ufficiale Europea: EN 1012-1, EN 60204-1, EN 61000-6-3, EN 61000-6-4
GB	Declares under its sole responsibility that the air compressor described below complies with all relevant regulations of the following EU directives: 2006/42/EC, 2014/30/EU The following harmonised standards have been applied in the latest version published on the Official Journal of the European Union: EN 1012-1, EN 60204-1, EN 61000-6-3, EN 61000-6-4
FR	Déclare sous son entière responsabilité que le compresseur d'air décrit ci-après est conforme à toutes les dispositions pertinentes des directives communautaires suivantes: 2006/42/CE, 2014/30/UE Les normes suivantes harmonisées dans la dernière version publiée au Journal Officiel de l'Union Européenne ont été appliquées: EN 1012-1, EN 60204-1, EN 61000-6-3, EN 61000-6-4
DE	Erklärt unter ihrer alleinigen Verantwortung, dass der in Folge beschriebene Luftkompressor allen einschlägigen Bestimmungen der folgenden EU-Richtlinien entspricht: 2006/42/EG, 2014/30/EU Die folgenden Harmonisierten Normen wurden in der jüngsten im Amtsblatt der Europäischen Union veröffentlichten Version angewendet: EN 1012-1, EN 60204-1, EN 61000-6-3, EN 61000-6-4
ES	Declara, bajo su exclusiva responsabilidad, que el compresor de aire descrito a continuación responde a todas las disposiciones pertinentes de las siguientes directivas comunitarias: 2006/42/CE, 2014/30/UE Se han aplicado las siguientes normas armonizadas en la última versión publicada en el Diario Oficial de la Unión Europea: EN 1012-1, EN 60204-1, EN 61000-6-3, EN 61000-6-4
PT	Declara sob a sua exclusiva responsabilidade que o compressor de ar descrito a seguir está em conformidade com todas as normas relevantes das seguintes diretivas da UE: 2006/42/CE, 2014/30/UE As seguintes normas harmonizadas foram aplicadas na última versão publicada no Jornal Oficial da União Europeia: EN 1012-1, EN 60204-1, EN 61000-6-3, EN 61000-6-4
NL	Verklaart onder zijneigen verantwoordelijkheid dat de hieronder beschreven persluchtcompressor voldoet aan alle voorschriften van de volgende EG-richtlijnen: 2006/42/EG, 2014/30/EU De volgende geharmoniseerde standaards zijn toegepast in de laatste versie gepubliceerd in het Publicatieblad van de Europese Unie: EN 1012-1, EN 60204-1, EN 61000-6-3, EN 61000-6-4
DK	Erklærer under eget ansvar, at luftkompressoren, der beskrives nedenfor, er i overensstemmelse med alle relevante forordninger fra de følgende EU-direktiver: 2006/42/EC, 2014/30/EU De følgende harmoniserede standarder gør sig gældende for den seneste version, som er offentliggjort i De Europæiske Fællesskabers Tidende: EN 1012-1, EN 60204-1, EN 61000-6-3, EN 61000-6-4
SE	Försäkrar under eget ansvar att den luftkompressor som beskrivs nedan överensstämmer med alla tillhörande föreskrifter i följande EG-direktiv: 2006/42/EG, 2014/30/EU Följande harmoniserade standarder har tillämpats i den senaste versionen, som publicerats i den Europeiska unionens officiella tidning: EN 1012-1, EN 60204-1, EN 61000-6-3, EN 61000-6-4
FI	Vakuuttaa omalla vastuullaan, että seuraavassa esitellyt ilmakompressorit vastaa kaikkia seuraavien Euroopan direktiivien vaatimuksia: 2006/42/EY, 2014/30/EU Seuraavia harmonisoituja normeja, joiden viimeisin versio on julkaistu Euroopan unionin virallisessa lehdessä, on sovellettu: EN 1012-1, EN 60204-1, EN 61000-6-3, EN 61000-6-4
GR	Δηλώνει με αποκλειστική δική της ευθύνη, ότι ο συμπιεστής αέρα που περιγράφεται παρακάτω συμμορφώνεται με όλες τις σχετικές διατάξεις των εξής κοινοτικών οδηγιών: 2006/42/ΕΚ, 2014/30/ΕΕ Εφαρμόστηκαν οι εξής εναρμονισμένοι κανονισμοί στην τελευταία έκδοση της Επίσημης Εφημερίδας των Ευρωπαϊκών Κοινοτήτων: EN 1012-1, EN 60204-1, EN 61000-6-3, EN 61000-6-4
PL	Oświadczca na swoją wyłączną odpowiedzialność, że opisana poniżej sprężarka spełnia wszystkie stosowne przepisy zawarte w następujących dyrektywach Unii Europejskiej: 2006/42/EC, 2014/30/UE Następujące ujednolicone normy mają zastosowanie w najbardziej aktualnej wersji opublikowanej w Dzienniku Urzędowym Unii Europejskiej: EN 1012-1, EN 60204-1, EN 61000-6-3, EN 61000-6-4
HR	Izjavljuje pod vlastitom odgovornošću da dolje opisani kompresor zraka udovoljava svim važećim propisima sljedećih Direktiva EU: 2006/42/EZ, 2014/30/EU Sljedeće usklađene norme primjenjuju se u najnovijoj verziji objavljenoj u Službenom listu Europske unije: EN 1012-1, EN 60204-1, EN 61000-6-3, EN 61000-6-4
SI	Izjavlja pod lastno odgovornostjo, da je v nadaljevanju opisan kompresor za zrak skladen z vsemi določili s področja naslednjih direktiv skupnosti: 2006/42/EU, 2014/30/EU Uveljavljeni so naslednji harmonizirani standardi zadnje verzije, objavljene v Uradnem listu Evropske skupnosti: EN 1012-1, EN 60204-1, EN 61000-6-3, EN 61000-6-4
HU	Kizárólagos felelőssége tudatában kijelenti, hogy a lent megnevezett kompresszor megfelel a következő EU irányelvek vonatkozó rendelkezéseinek: 2006/42/EK, 2014/30/EU Az alábbi harmonizált szabványokat az Európai Unió Hivatalos Lapjában közzétett legutóbbi változatuk szerint alkalmaztuk: EN 1012-1, EN 60204-1, EN 61000-6-3, EN 61000-6-4
CZ	Prohlašuje s plnou odpovědností, že uvedený vzduchový kompresor splňuje všechna příslušná nařízení následujících směrnic EU: 2006/42/ES, 2014/30/EU Použity byly následující harmonizované normy publikované v Úředním věstníku Evropské unie v nejnovějších verzích: EN 1012-1, EN 60204-1, EN 61000-6-3, EN 61000-6-4
SK	Vyhlasuje na vlastnú zodpovednosť, že uvedený vzduchový kompresor spĺňa všetky príslušné nariadenia nasledujúcich smerníc EÚ: 2006/42/ES, 2014/30/EU Boli použité nasledujúce harmonizované normy publikované v Úradnom vestníku Európskej únie v najnovších verziách: EN 1012-1, EN 60204-1, EN 61000-6-3, EN 61000-6-4
RU	Заявляет под свою исключительную ответственность, что воздушный компрессор, описанный ниже, отвечает всем соответствующим положениям следующих европейских директив: 2006/42/EC, 2014/30/EU Следующие гармонизированные стандарты были применены в последней редакции, опубликованной в правительственном вестнике ЕС: EN 1012-1, EN 60204-1, EN 61000-6-3, EN 61000-6-4
NO	Erklærer under eget ansvar at luftkompressoren her beskrevet er i overensstemmelse med alle krav i de følgende EU-forskriftene: 2006/42/EC, 2014/30/EU De følgende harmoniserte standardene er brukt i den siste versjonen trykt i den Den europeiske unions tidende (EUT): EN 1012-1, EN 60204-1, EN 61000-6-3, EN 61000-6-4
TR	Tek sorumluluk kendisinde olmak üzere, aşağıda açıklanan hava kompresörünün, izleyen AB direktiflerinin ilgili tüm yönetmeliklerine uygun olduğunu beyan eder: 2006/42/EC, 2014/30/EU Avrupa Birliği'nin Resmi Gazetesinde yayınlanan son sürümde, aşağıdaki uyumlaştırılmış standartlar uygulanmıştır: EN 1012-1, EN 60204-1, EN 61000-6-3, EN 61000-6-4
RO	Declară pe propria răspundere că compresorul de aer descris în continuare este conform cu toate dispozițiile în materie ale următoarelor directive comunitare: 2006/42/CE, 2014/30/UE Au fost aplicate următoarele standarde armonizate în ultima versiune publicată în Jurnalul Oficial al Uniunii Europene: EN 1012-1, EN 60204-1, EN 61000-6-3, EN 61000-6-4
BG	Декларира на собствена отговорност, че описаният по-долу въздушен компресор отговаря на всички съответни разпоредби на следните директиви на ЕС: 2006/42/EC, 2014/30/EC Следните хармонизирани стандарти са приложени в най-новото издание, публикувано в Официален вестник на Европейския съюз: EN 1012-1, EN 60204-1, EN 61000-6-3, EN 61000-6-4
RS	Izjavljuje pod ličnom odgovornošću da je dole opisan kompresor vazduha u skladu sa svim važećim propisima sledećih Direktiva EU: 2006/42/EZ, 2014/30/EU Sledeće usklađene norme primenjuju se u najnovijoj verziji objavljenoj u Službenom glasniku Evropske unije: EN 1012-1, EN 60204-1, EN 61000-6-3, EN 61000-6-4
LT	Su visa atsakomybe pareiškia, kad žemiau aprašytas oro kompresorius atitinka visus taikomus reglamentus, apibrėžtus šiose ES direktyvose: 2006/42/EB, 2014/30/ES Toliau nurodyti darnieji standartai buvo pritaikyti naujausioje versijoje, publikuotoje Europos Sąjungos oficialiajame leidinyje: EN 1012-1, EN 60204-1, EN 61000-6-3, EN 61000-6-4
EE	Avaldab enda täieliku vastutusega, et järgnevalt kirjeldatud õhukompressor vastab kõigile järgmistel EL-i direktiivide eeskirjadele: 2006/42/EÜ, 2014/30/EÜ Euroopa Liidu Teatajas avaldatud uusimas versioonis on kohaldatud järgmisi ühtlustatud standardeid: EN 1012-1, EN 60204-1, EN 61000-6-3, EN 61000-6-4
LV	Pilnībā apstiprina, ka tālāk minētais gaisa kompresors atbilst visiem šādu ES direktīvu noteikumiem: 2006/42/EK, 2014/30/ES Jaunākajai versijai, kas publicēta Eiropas Savienības oficiālajā laikrakstā, ir piemēroti šādi vienotie standarti: EN 1012-1, EN 60204-1, EN 61000-6-3, EN 61000-6-4

INDEX

DECLARATION OF CONFORMITY	2
GENERAL INFORMATION.....	3
OVERALL DIMENSIONS	4
SAFETY INDICATIONS.....	9
INSTALLATION	11
TECHNICAL FEATURES	12
CONTROLS AND SETTINGS	13
ALARMS.....	15
OPERATION.....	16
MAINTENANCE	17
TROUBLE SHOOTING	20
WIRING DIAGRAM	21

OUTFIT

The following accessories are supplied with the compressor:

- user's guide,
- anti-vibration elements,
- oil/condensate exhaust tube,
- air outlet cock.

Check that the above accessories are available. Once the goods have been delivered and accepted, no complaints are accepted.

CONDITION OF THE MACHINE WHEN SUPPLIED

Every compressor is shop tested and delivered ready to be installed and to be set at work.

Oil used is: FSN Original Oil.

OVERALL DIMENSIONS

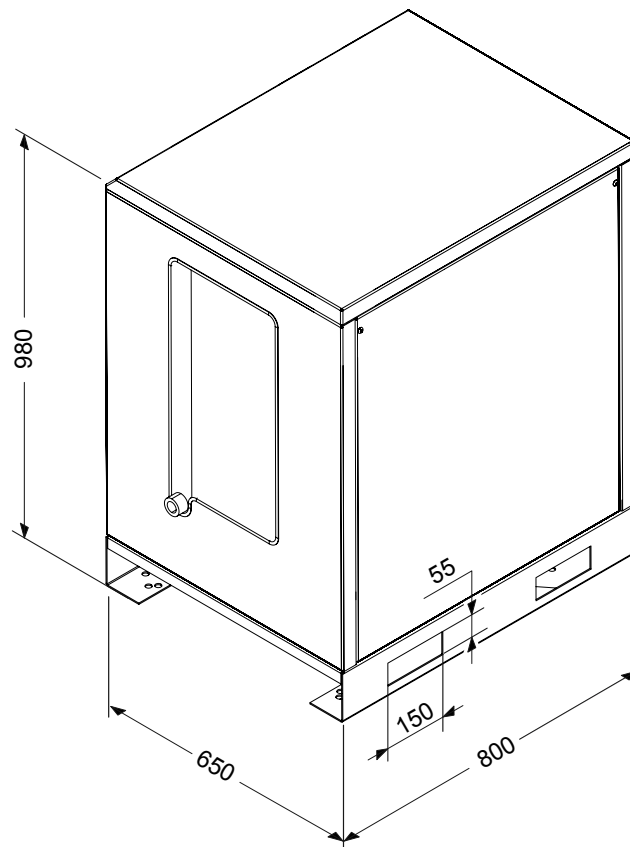
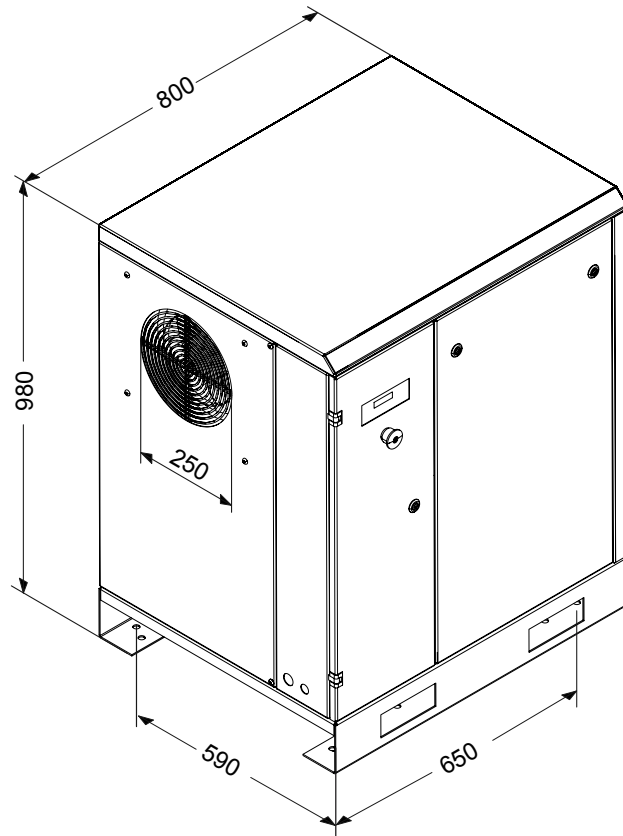

OVERALL DIMENSIONS

EN

270 Lt.

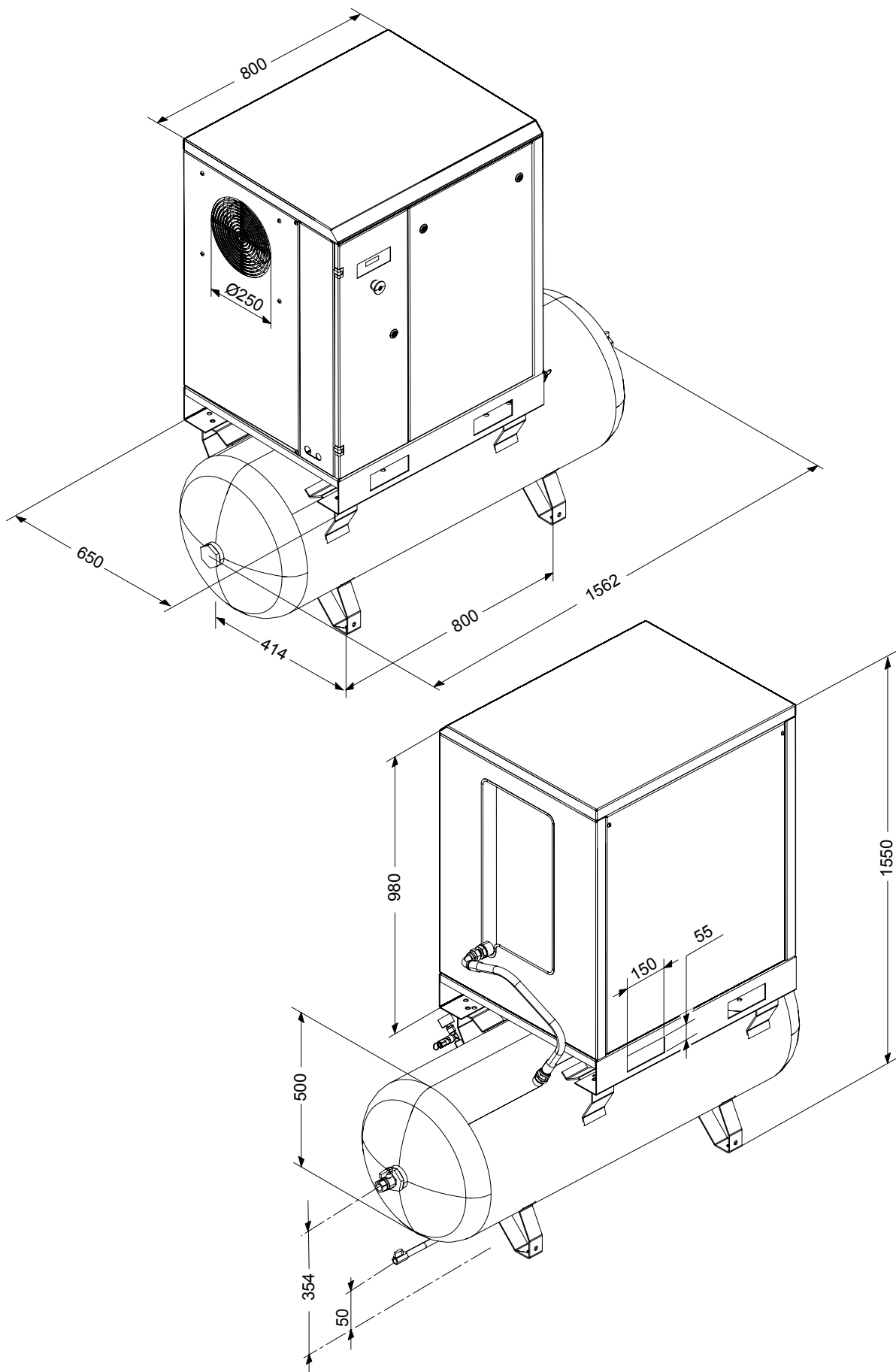

OVERALL DIMENSIONS

270 Lt. + dryer

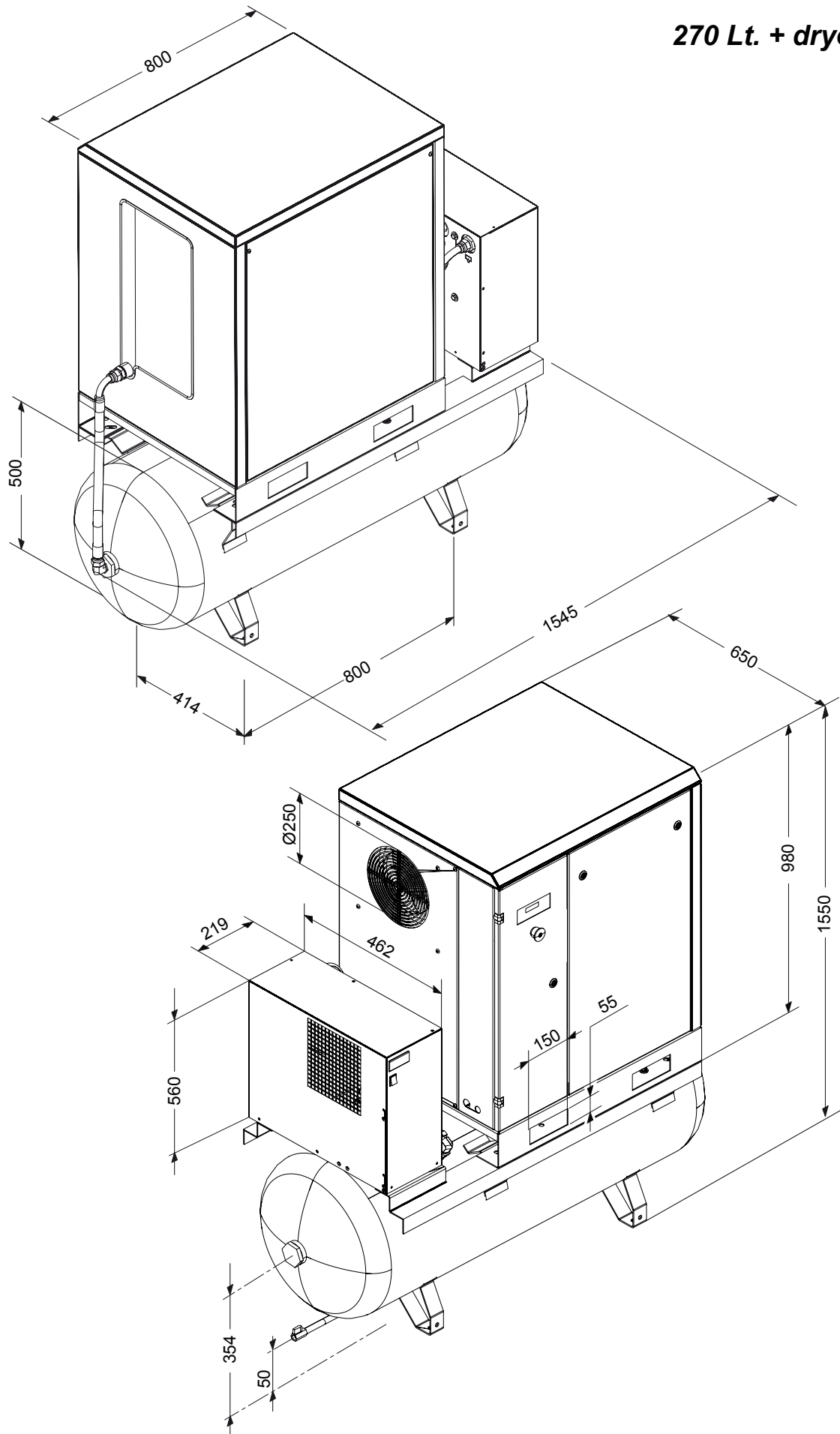

OVERALL DIMENSIONS

500 Lt.

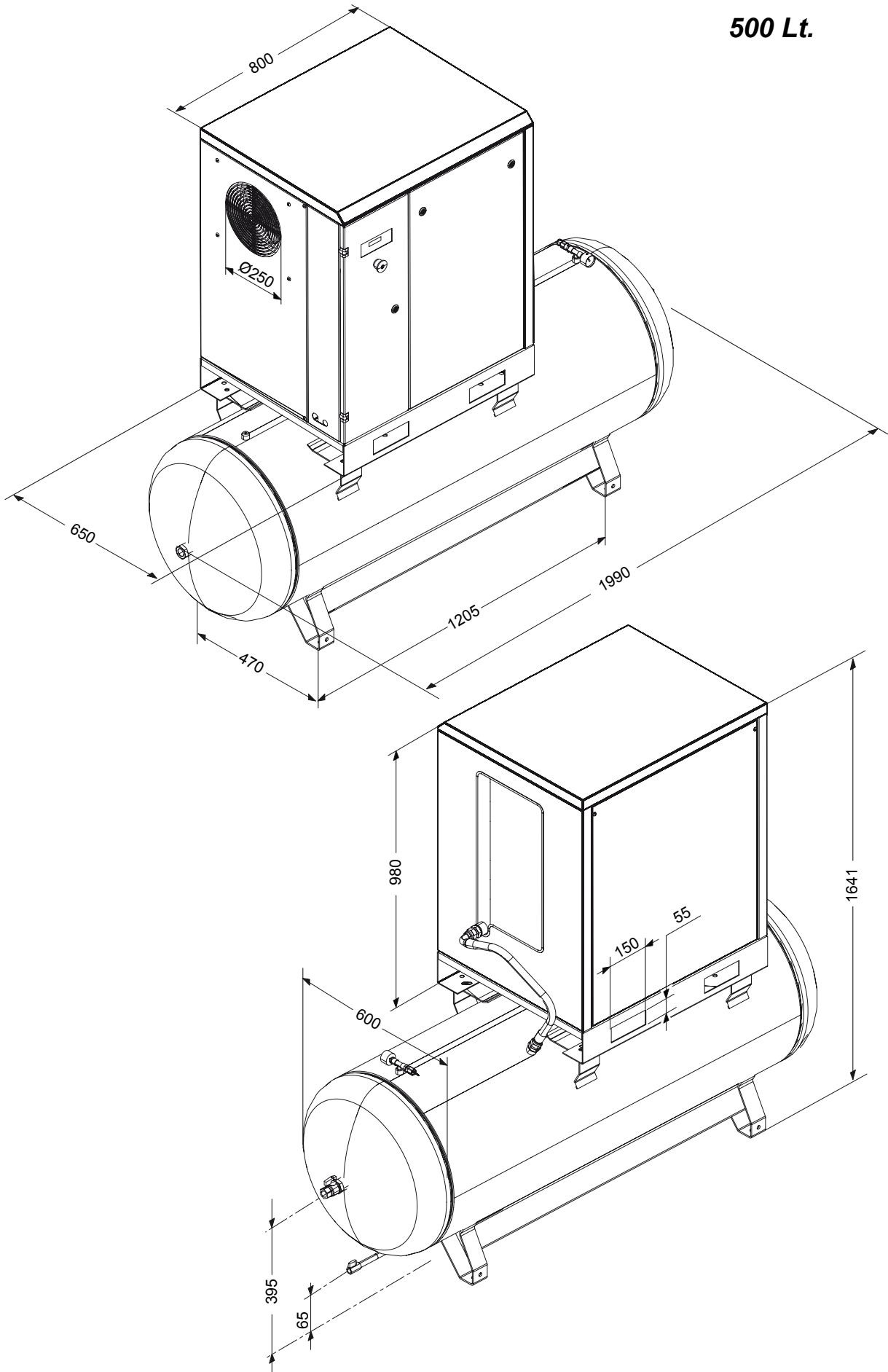

OVERALL DIMENSIONS

500 Lt. + dryer

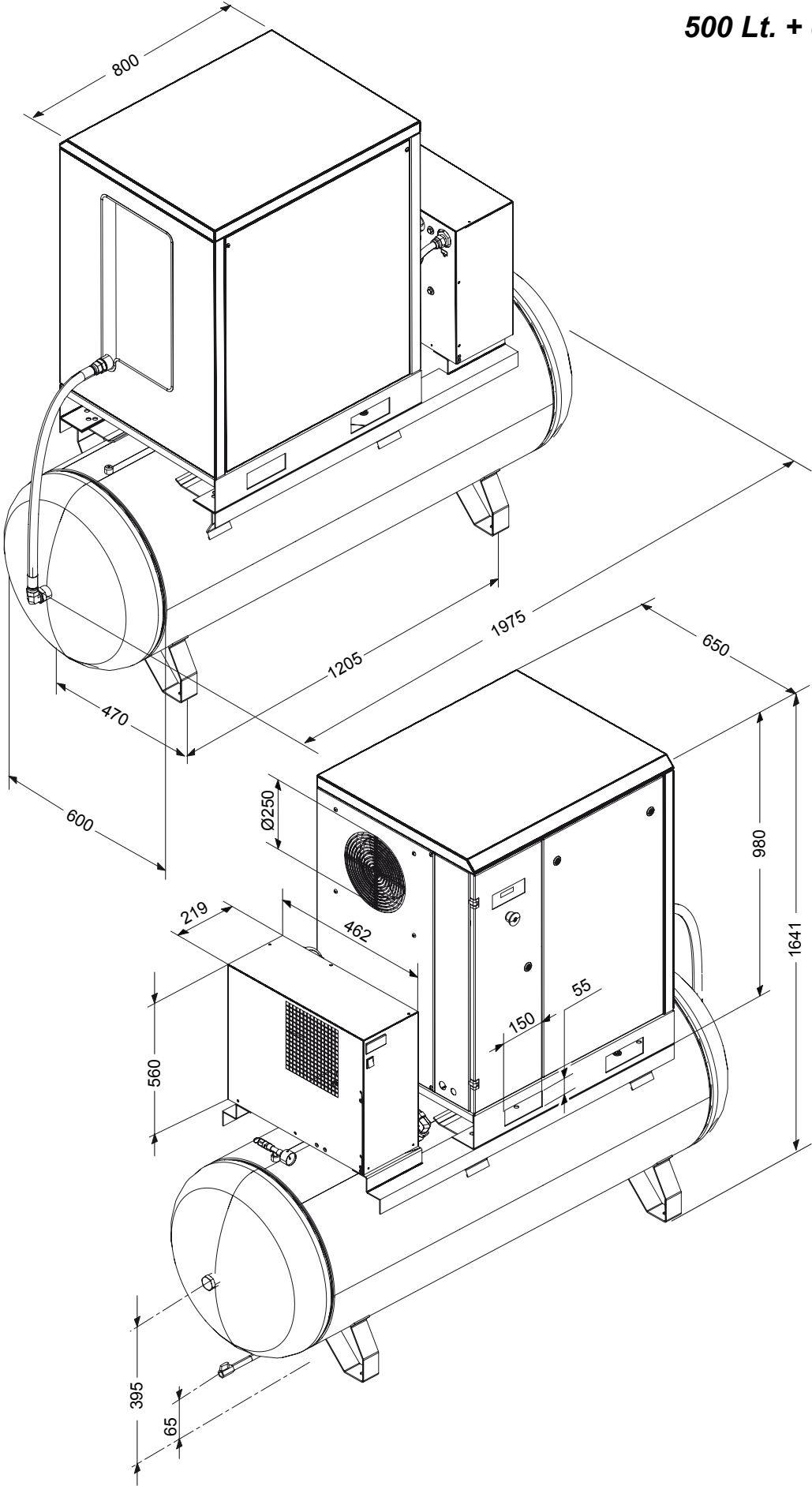

GENERAL WARNINGS

- The rotating compressors are destined for arduous and continuous industrial use. They are particularly adapt for application in industries where a large consumption of air is requested for long periods of time.
- The compressor must be used exclusively as indicated in this manual, which must be kept carefully in an easily accessible place known to everyone, as it must remain with the machine for its entire duration.
- The company in which the compressor is to be installed must appoint a person in charge of the compressor itself. Controls, adjustments and maintenance interventions are under his responsibility: if this person must be replaced, the substitute must read the user and maintenance manual and any notes made regarding technical and maintenance interventions carried out up to this time.

SYMBOLS USED IN THE MANUAL

Several symbols have been used inside the manual, which highlight dangerous situations, give practical advice or simple information. These symbols are found at the side of a text, at the side of a figure or at the top of a page (in this case they refer to all subjects considered on the entire page).

Pay attention to the meaning of the symbols.



ATTENTION!

Highlights an important description regarding: technical interventions, dangerous conditions, safety warnings, advice and/or very important information.



REMOVE VOLTAGE!

It is compulsory to deactivate the electric power supply to the machine before carrying out any interventions on the machine.



MACHINE AT A STANDSTILL!

Every operation highlighted by this symbol must only be carried out with the machine at a standstill.



SPECIALISED STAFF!

All interventions highlighted with this symbol must be carried out exclusively by a specialised technician.

SYMBOLS USED ON THE COMPRESSOR

Several different labels are applied to the compressor. Their function is most of all to highlight any hidden dangers and to indicate correct behaviour during use of the machine or in particular situations.

It is of fundamental importance that they are respected.

Warning symbols



High temperature risk



Electric shock risk



Risk from hot or dangerous gases in the work area



Pressurised container



Moving mechanical parts



Maintenance in progress



Machine with automatic start-up

Prohibition symbols



Do not open hatches when the machine is functioning



If necessary, always use the emergency stop button and not the line isolating switch



Do not use water to put out fires on electrical appliances

Obligation symbols



Carefully read the user instructions

TO DO:

Make sure that mains voltage corresponds to the voltage indicated on CE plate and that cable of suitable cross-section are used for electric connections.

Always check oil level before starting the compressor.

Be familiar with emergency stop control and all other controls.

Unplug the connector before any maintenance work, so to avoid accidental start.

Ensure that all parts have been correctly reassembled after any maintenance work.

Keep children and animals off the working area to avoid injuries caused by devices connected to the compressor.

Ensure that temperature of the working environment ranges between +2 and + 45 °C. Compressor working temperature shall range between 70÷85°C (20-25°C room temperature). Lower temperatures may causes condensate accumulation inside the oil separator tank (inside the compressor). **Check for condensate and if necessary, drain it (see maintenance).**

The compressor should be installed and operated in a non-explosive environment.

Allow at least 80 cm between the compressor and the wall so to allow free air flow to the fan.

Press the emergency button on the control panel only in case of actual need so as to avoid possible damages to people or the very compressor.

When calling for technical assistance and/or advice, always mention model, code and serial number indicated on CE plate.

Always follow the maintenance schedule specified in the user's guide.

DO NOT:

Do not touch inner parts and pipes as they are very hot during compressor operation and stay hot for a certain time after compressor stops.

Do not position inflammable close to and onto the compressor.

Do not move the compressor when the tank is under pressure.

Do not operate the compressor if the power cable is damaged or defective or if connection is unstable.

Do not operate the compressor in wet or dusty environments.

Never aim the air jet at people or animals.

Do not allow unauthorized people to operate the compressor and give them all required instructions.

Do not hit fans with blunt objects as they might break during compressor operation.

Never operate the compressor without air filter.

Do not tamper with safety and adjusting devices.

Never operate the compressor when doors/panels are open or removed.

Do not strike the fans with contusive or metal objects as they could cause sudden breakage during functioning.

Do not allow the compressor to function without the filter and/or air pre-filter.



Do not tamper with safety and adjustment devices.

Never allow the compressor to function with the hatches/panels open or removed.

PRODUCT IDENTIFICATION

The compressor You have purchased has its own CE plate showing the following data:

1. Manufacturer's data
2. Year of manufacture
3. TYPE = name , CODE = code , SERIAL NO. = serial number (to be always mentioned when calling for technical assistance)
4. Tech data: air intake/air delivery, Max. operating pressure, Tank capacity , Rotations per minute, weight.
5. Voltage , frequency , absorption, power.
6. Noise level

		CE		
TYPE				
CODE				
S/N				
L/MIN			bar =	
CFM			psi =	
Lwa =	Lwa m =	Tank =		
		RPM		
		Kg =		
⚠	V =	Hz =	A =	kW =
				HP =
				20....

DESCRIPTION OF THE COMPRESSOR

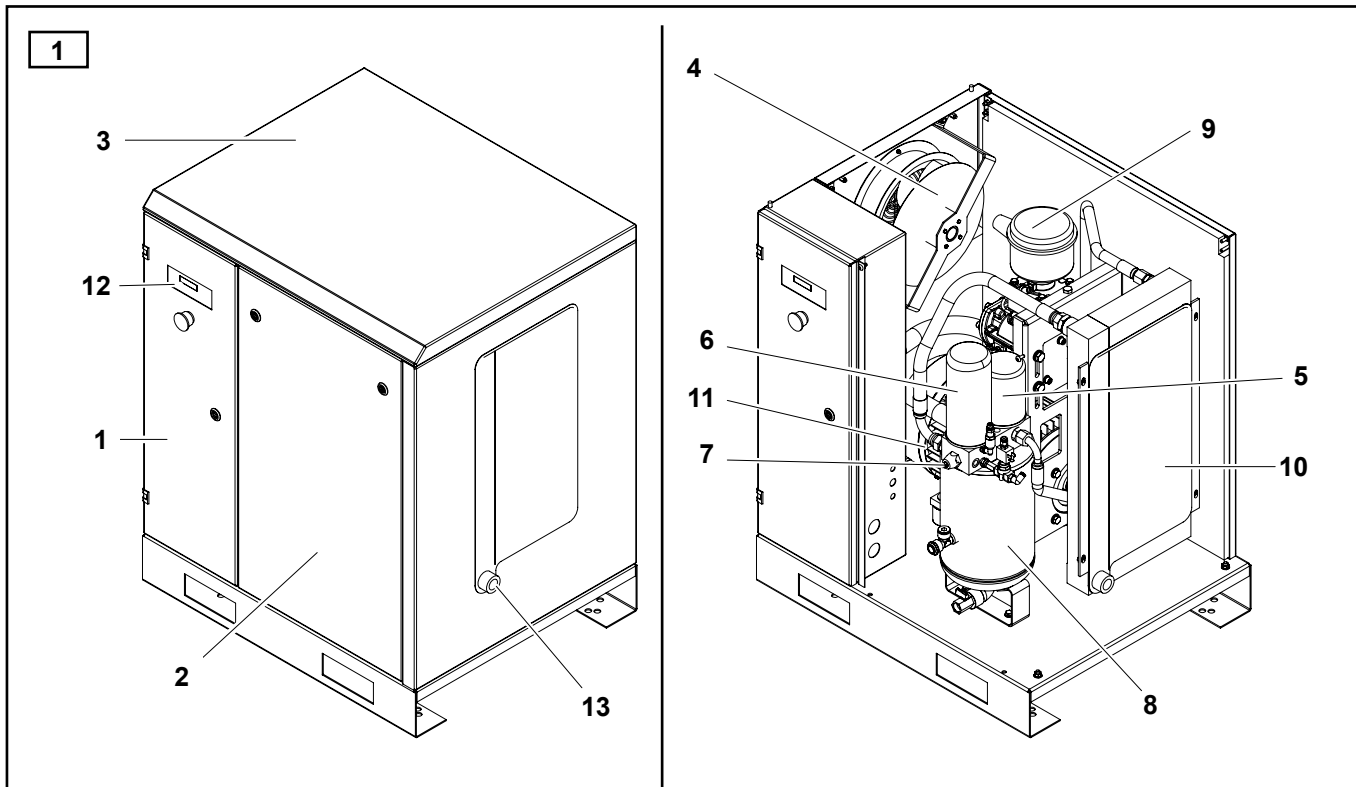

- | | |
|--------------------------------------|---|
| 1) Electrical equipment | 8) Oil separator tank |
| 2) Front panel / Oil indicator level | 9) Air filter / Intake regulator / Screw compressor |
| 3) Lid | 10) Oil radiator |
| 4) Electric fan | 11) Electric motor |
| 5) Oil filter | 12) Control panel |
| 6) Oil separator filter | 13) Air intake outlet |
| 7) Minimum pressure valve | |

UNPACKING AND HANDLING THE MACHINE

When delivered, compressor top is protected by cardboard packing.

Wear suitable protective gloves and then cut outer straps and then remove cardboard from the top. Check the (outer) good condition of the machine before moving the compressor. Visually check that no parts are damaged. Also ensure that all accessories are available.

Lift the machine using a fork lift truck. Fit the anti-vibration elements into their proper seat and move the machine to the room chosen for its location with maximum care.

Keep all packing materials at least for the warranty period for possible moving. In case of need, it will be safer for delivery to the technical assistance dept.

Then, dispose of packing materials in compliance with current laws.

LOCATION (fig. 2)

The room chosen for the installation of the compressor should meet the following requirements and comply with what is specified in the current safety and accident prevention regulations:

- **low percentage** of fine dust,
- **proper room ventilation and size** that allow room temperature under 45°C. In the event of inadequate hot air discharge, fit the exhaust fans as high as possible.

Condensate should be collected either into a pit or a tank.

The dimensions of the spaces are indicative only but it is advisable to follow them as closely as possible.

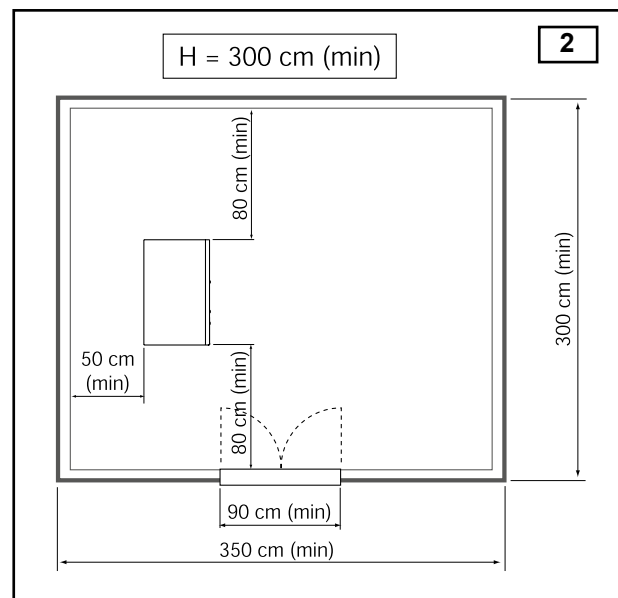



ELECTRICAL HOOK-UP (fig. 3)

- The mains cable should have a cross-section suitable for the machine power and should include no. 3 phase wires, no. and no. 1 earth wire.
- Between the mains cable and the compressor control panel a fused switch near the point where the cables go into the machine **is absolutely necessary**. The switch should be at least at 1.7 m from the ground.
- The switch (A) should be easily reached by the operator. The cables should be of the approved type and installed with the following grade of protection: minimum IP44.

N.B. To determine the cables cross-section follow the sizing indications in compliance with the "VDE 0100, Part 430 and 523" Standard, star-delta starter, 30 °C room temperature and cable length lower than 50 meters.

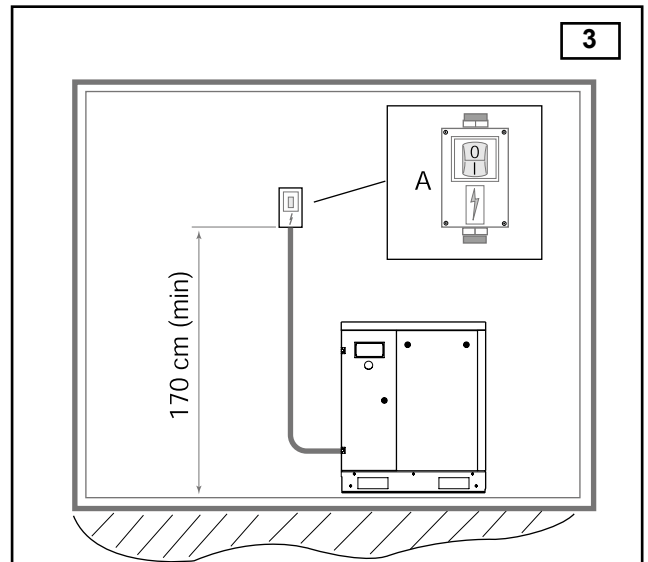

TECHNICAL FEATURES

Technical characteristics	Type	8			11			15			16		
		bar	g		8	10	13	8	10	13	8	10	13
Work pressure	bar g	8	10	13	8	10	13	8	10	13	8	10	13
Pump group	type	FS26TF			FS26TF			FS26TF			FS50TF		
Air outflow rate (according to ISO 1217 annex C)	l/min	1250	1000	750	1650	1500	1150	2150	1850	1550	2350	2050	1700
Oil quantity	l	6,5			6,5			6,5			6,5		
Quantity of top up oil	l	0,8			0,8			0,8			0,8		
Max final air temperature above ambient	°C	10			12			15			17		
Heat carried	kJ/h	25600			37600			51300			51300		
Fan flow rate	m ³ /h	1500			1500			2000			2000		
Oil residuals in the air	mg/m ³	2-4			2-4			2-4			2-4		
Electric motor	type	132 B3B14			132 B3B14			132 B3B14			132 B3B14		
Nominal Input	kW	7,5			11			15			15		
Max input power from the mains	kW	8,9			12,9			15,9			17,1		
Electric box protection level	IP	54			54			54			54		
Ambient temperature limit	°C	+2/+45			+2/+45			+2/+45			+2/+45		
Sound pressure (according to Pneurop/Cagi PN2CPTC2)	dB(A)	68			69			70			68		

Electrical data					
Voltage power supply	V/Ph/Hz	400/3~/50		400/3~/50	
Auxiliary voltage	V/Ph/Hz	24/1~/50		24/1~/50	
Current input at start up	A	36		59	
Max current input	A	15,5		24	
Idle running absorbed power	kW	3,8		5,1	
Electric motor protection degree	IP	55		55	
Insulation class		F		F	
Service factor		1,1		1,1	

Protection devices					
Oil circuit max temperature	°C	110		110	
Pre-alarm oil temperature calibration	°C	105		105	
Thermal motor relay calibration	A	10,5		14,5	
Safety valve calibration	bar	14		14	

Dimensions					
Length	mm	800		800	
Width	mm	650		650	
Height	mm	980		980	
Weight	kg	190		210	
Air outlet	G	3/4"		3/4"	

CONTROL PANEL

The version is equipped with an electronic control called which manages all of the compressor functions

1. START key:
controls start up of the compressor.
2. RESET key:
controls turning off of the compressor.
3. "Function" key:
allows movement from one display to the other.
4. Display:
shows the information.
5. Alarm warning lights:
turn on in case of alarm.
6. Screw warning light:
turning on means that the compressor is loading.
7. Stand-by warning light:
turning on indicates the compressor is waiting.
8. Emergency shutdown button:
pressing this button causes immediate stoppage of the compressor. **To be used only and exclusively** in the event of real need.

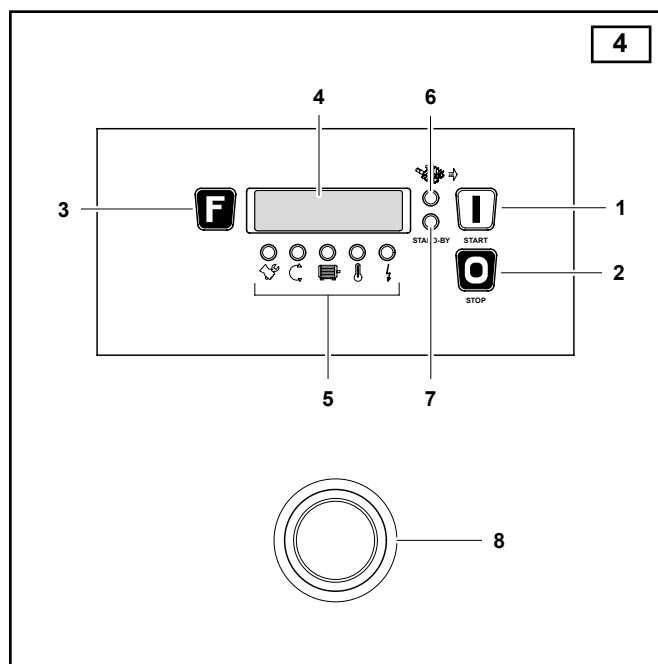

WORKING TIMES

- START-STOP function: the compressor starts from the pressure switch command. When maximum pressure is reached it stops and restarts automatically only if the minimum pressure value allowed is reached.
 - The compressor function is regulated by the electronic control unit, which measures the pressure by means of a pressure transducer and determines the stopping of the machine when the maximum pressure is reached (vacuum pressure) and it restarts when the pressure decreases to the minimum calibration level (load pressure)
 - The machine stop is a delayed type that does not occur at exactly the same time as reaching maximum P value but after a certain time (idle time), during which no air is taken.
 - The factory idle time is 75 seconds but check that the n° of switch on per hour DO NOT exceed the max advised n° of 10. If above 10, increase the "idle time", in order to avoid not necessary switch on and switch off cycles.

PRESSURE REGULATOR

The User should install an intercepting and regulating device downstream of the compressor in order to set the air distribution line according to his/her needs.



CONTROLS AND SETTINGS

MODIFIABLE PARAMETERS

These settings apply exclusively to the models fitted with power unit.

User menu

With the compressor off, keep the "Function" key pressed for at least 5 seconds.

N°	Parameter	U.M	Min. value	Default value	Max value
U0	Set loadless pressure (*)	Bar	0.5	10.0	15.0
U1	Set loading pressure (**)	Bar	0	8.5	(Set P loadless) – 0.5
U2	Unit of measure (***)	Bar/Psi	0	1	1

- to select the parameter desired use START (forward) and RESET (back) keys,
- then press the FUNCTION key to show the value of the chosen parameter,
- to change the value use START (to increase) and RESET keys (to decrease),
- confirm the value set by pressing the FUNCTION key.
- The power unit returns to the main menu, and after 5 seconds without pressing any key it returns to the standard display.

(*) Set loadless pressure: indicates the value of pressure at which the compressor starts the loadless operating cycle.

(**) Set loading pressure: indicates the value of pressure at which the compressor starts compressing air again.

(***) 1=bar, 0=psi

Assistance menu

The settings below must be performed only by authorised technicians.

With the compressor off or in alarm status, keep the "FUNCTION" and "RESET" buttons pressed for at least 5 seconds, then a password will be requested.

N°	Parameter	U.M	Min. value	Default value	Max value
A0	Temperature to power fan	°C	0	80	150
A1	Time loadless	sec.	30	75	900
A2	Delay time in stoppage phase	sec	30	60	900
A3	Enable pressure sensor (*)		0	1	1
A4	Enable temperature sensor (*)		0	1	1
A5	Enable automatic start (*)		0	0	1
A6	Enable phase sequence (*)		0	1	1
A7	Expiry oil hours	hours	0	2000	65536
A8	Expiry oil filter hours	hours	0	2000	65536
A9	Expiry air filter hours	hours	0	1000	65536
A10	Expiry oil separator hours	hours	0	2000	65536
A11	Total hours (**)	hours	0	—	65536
A12	Loading hours (**)	hours	0	--	65536

(*) 1=enabled, 0=disabled

- to select the parameter desired use START(forward) and RESET keys (back),
- then press the FUNCTION key to show the value of the chosen parameter,
- to change the value use START (to increase) and RESET keys (to decrease),
- confirm the value set by pressing the FUNCTION key.
- The power unit returns to the main menu, and after 5 seconds without pressing any key it returns to the standar display.

ALARMS

During normal operation of the compressor the following signals can occur:

Alarm warning lights (rif.5, fig.5)



Maintenance
The warning light indicates that maintenance is required.



The warning light turns on to indicate a wrong electrical connection. The compressor blocks.
Check connection to the mains cable and to the terminals of the electrical panel of the compressor.



Oil temperature.
Blinking warning light = pre-alarm without compressor block
Fixed warning light = alarm with compressor block
Let the compressor cool down and check the oil level.



The maximum temperature of the motor has been exceeded. The compressor blocks.
Let the motor cool down and check setting of thermal relay.



Indicates there has been a blackout. The compressor blocks.
With compressor stopped, press RESET to disable the alarm before restarting.

Alarm messages, the following alarms are shown on screen:

- | | |
|-----|--|
| AL1 | Faulty or broken temperature sensor with blockage of compressor.
Replace sensor. |
| AL2 | Faulty or broken pressure sensor with blockage of compressor.
Replace sensor. |
| AL3 | No phase or phase sequence transformer not operational with blockage of compressor.
Check presence of phase and if necessary replace transformer. |
| AL4 | Maximum alarm pressure with blockage of compressor.
Contact an assistance centre to remove the cause of the problem. |
| AL5 | Fast rise in temperature with blockage of compressor.
Contact an assistance centre to remove the cause of the problem. |
| AL6 | The emergency button has been pressed.
Reset the button to correct position. |

All alarms cause the compressor to block, which can be restarted only when the problem which has caused the blockage is resolved.

The alarm signal remains even after the problem has been solved, to disable it press the RESET button before restarting the compressor.

Maintenance signalling

The power unit also signals periodic maintenance operations, the internal counters decrease at each hour of loading of the compressor until zero is reached, at this point the maintenance signal will appear on the display:

- | | |
|-----|--|
| CH1 | Expiry of oil hours.
Replace oil. |
| CH2 | Expiry of oil filter hours.
Replace oil filter |
| CH3 | Expiry air filter hours
Replace air filter. |
| CH4 | Expiry of oil separator hours
Replace oil separator filter. |

If more signals are verified at the same time they are displayed in sequence.
Once the maintenance has been performed the internal counters must be reprogrammed.



Before starting the machine for the first time, **check that:**

- the mains voltage is the same as the voltage on the CE plate;
- the electric connections have been made using cables of proper cross-section,
- the (wall) main power switch has suitable fuses;
- the oil level is over the minimum level - top up with the same type of oil if necessary;

CONNECT THE TANK WITH A HOSE.

Only specialised technicians can start the compressor for the first time.

ON/OFF (fig.4): Before starting up the machine remove the rear panel, switch on the machine by positioning switch (2) in the ON position and check the correct rotating direction of the motor, as indicated by the arrows applied on the screw-motor plate (fig.6).

If the rotation direction is not correct the compressor does not start; a warning sound and a light on the electronic thermostat (inside the electrical compartment) alert to the issue.

Immediately switch off the machine taking both the switch (2) and the wall switch to the OFF position. Open the electric compartment and invert the position of the electric cables of the two phases in the powering terminal board.

Close the electric compartment and restart.

SD STAR-DELTA (fig.5): The **turning on procedure** starts by pressing the START key (1).

The Stand-by led (7) blinks and after a few seconds the presence of the phases and their correct sequence is checked.

If the compressor does not start and the light  comes on, the phase sequence device has intervened, press the RESET (2) button and set the wall mounted switch to the OFF position.

Open the electric compartment and invert the position of two phases in the power terminal box. Close the electrical compartment and restart.

The start up procedure is repeated: the Screw led (6) blinks and after a few seconds it becomes fixed, the load phase starts until the "set loadless pressure" value is reached.

The Screw led (6) blinks again and the loadless operation phase begins.

If at the end of the loadless operation (default 75 sec.) the pressure has not fallen below the "set load pressure" value the compressor stops and the Stand-by led turns on (7); otherwise upon reaching the "set load pressure" value the compressor restarts the loading phase and the Screw led turns on in fixed mode (6).

During normal function, press the Function key (3). The following information will be displayed:

- pressure,
- temperature,
- total hours of operation (with compressor on),
- hours of operation loaded (with compressor in load phase).

By pressing the RESET key (2) the **turn off procedure** starts, the Screw led (6) blinks and the compressor enters the loadless operation mode for the time set by the parameter "delayed stop time" (default 60 sec.). At the end of the cycle the compressor stops.

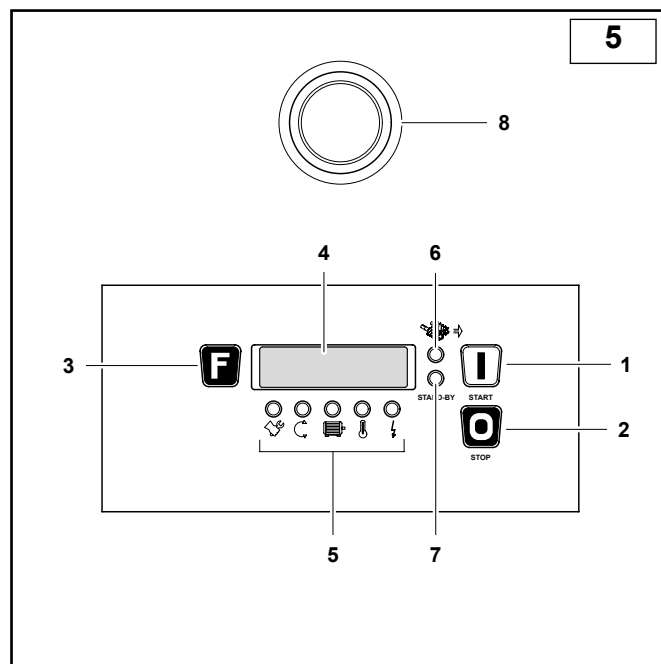

FUNCTIONING CYCLE

- Correct maintenance is crucial to achieve maximum efficiency of your compressor, and to lengthen its operating life.
- It is also important to comply with the maintenance intervals recommended, but it must be remembered that such intervals are suggested by the manufacturer in the event that the environmental conditions of use of the compressor are optimal (see "Installation" chapter).
- The maintenance intervals can therefore be reduced depending on the environmental conditions in which the compressor operates.
- The oil used is FSN Original Oil, the use of a different oil does not guarantee perfect efficiency and compliance with the maintenance intervals.
- The following pages describe the routine maintenance operations which can be performed by the person in charge of the compressor, the non-routine maintenance operations must instead be performed by an authorised technical assistance centre.



Maintenance table

MAINTENANCE OPERATION	MAINTENANCE INTERVAL	
	working hours	o at least
<i>ROUTINE MAINTENANCE</i>		
Condensate drain for oil tank	-	once a week
Check oil and possible top up	500	once a month
Clean filtering element	500	once a year
Check the tension of the transmission belt	500	once a year
Check blockage and clean radiator	1000	once a year
Replace the filtering element	1000	once a year
Replace oil filter	2000*	once a year
Replace oil separator filter	2000*	once a year
Replace oil	2000*	once a year
<i>NON-ROUTINE MAINTENANCE</i>		
Clear/Replace one-way drain valve	4000	once a year
Review suction valve	4000	-
Review minimum pressure valve	8000	-
Replace the transmission belt	8000	-
Replace hoses	8000	-
Replace solenoid valve	12000	-
Electric motor bearings replacement	12000	-
Review screw	20000	-
* If mineral oil is used, the maintenance intervals indicated in this table, in terms of operating hours, must be halved, and the maintenance must be performed at least once a year.		

If the hourly limit is not reached, the maintenance operations highlighted in **bold** must be performed at least **once a year**.

• To verify correct machine operation, perform the following checks **after the first 100 hours of work**:

- 1) **Check the oil level**: top up with the same type of oil if necessary.
- 2) **Check for proper screw tightening**: in particular the power electric connection screws.
- 3) Visually check that all **fittings seal properly**.
- 4) Check the **belt tension** and if necessary, reset it.
- 5) Check the **hours of work** and the **type of service selected**
- 6) Check **room temperature**.

BEFORE MAINTAINING THE MACHINE ALWAYS PERFORM THE FOLLOWING:

- √ **Press the machine automatic stop button** (do not use the emergency button).
- √ Power the machine off by means of the wall outer switch.
- √ Close the line cock.
- √ Make sure that no compressed air is inside the oil separator tank.
- √ Remove fairing and/ or panels.



DRAIN CONDENSATE (Fig.6)

The oil/air mixture cooling is set at a higher temperature with respect to the dew point of the air (under standard operating conditions of the compressor). However, the condensate in the oil cannot be fully removed.

Blow off compressed air through cock **B** and then close it as soon as oil begins to flow out instead of water. Check the oil level and top up if necessary

CONDENSATE IS A POLLUTING MIXTURE! It must not be let into the sewage.

OIL CHECK AND TOP UP IF NECESSARY

(Fig.6)

With the compressor off, check the oil level by means of the warning indicator positioned on the front panel 2.

If the level is under the minimum, remove the front panel and refill through hole **A**. Quantity of oil for refilling from the min to the max level = 0.5 litres.

Use **ONLY** oil of the same type (FSN Original Oil).

CLEANING/REPLACING THE FILTERING ELEMENT (Fig.7)

With the compressor stopped, remove the lid and carefully clean the filtering element **D** using compressed air from the inside towards the outside. Check, against the light, for the presence of possible tears and if necessary, replace it.

The filtering element and the lid should be mounted with care, so that no dust can enter the compression unit.

Never allow the compressor to function without the filtering element.

Replace the filtering element D. Alarm signal CH3

CLEANING THE RADIATOR

It is recommended that in case of over temperature anomalies and however, at least once a year that the radiator is cleaned.

Proceed as follows:

position a sheet of protective plastic under the radiant pack;
spray (with a washing + detergent gun) from inside towards the outside.

Check that the air flows correctly by means of the radiator.

REPLACING THE OIL FILTER (Fig.8)

With the compressor stopped, remove the lid and the front panel.

Alarm signal CH2

At each change replace also the oil filter **E**, unscrew the old filter and replace it. Always apply some oil on the edge of the filter and on the seal before refitting manually the filter.

REPLACING THE SEPARATOR FILTER (Fig.8)

With the compressor stopped, remove the lid and the front panel.

Alarm signal CH4

The oil separator filter **F** cannot be cleaned, but must be replaced.

Unscrew filter manually (or if necessary use an appropriate filter tool) turning it anticlockwise.

After having slightly greased the oil separator filter seal and O-ring, fit the new filter by turning clockwise.

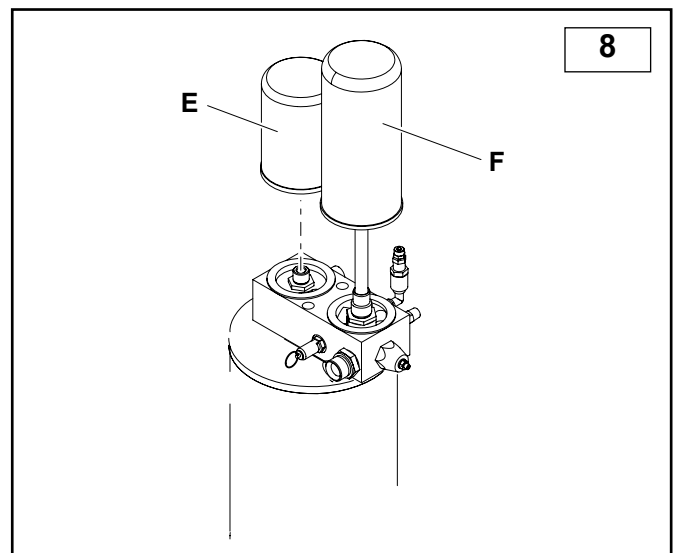
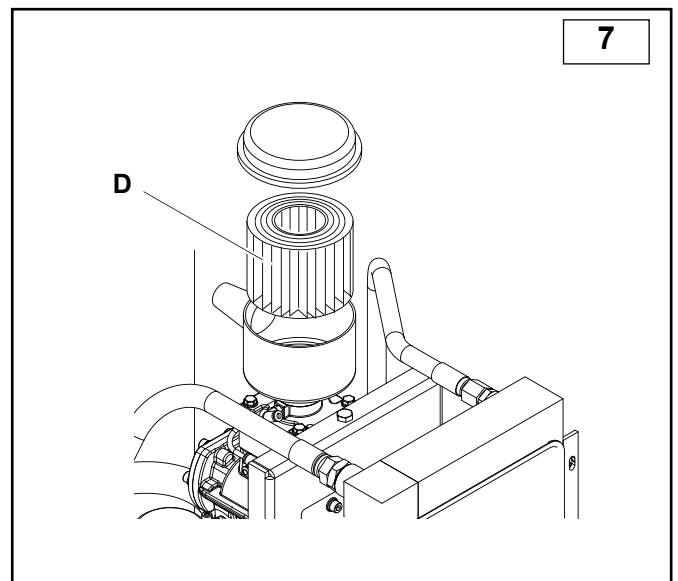
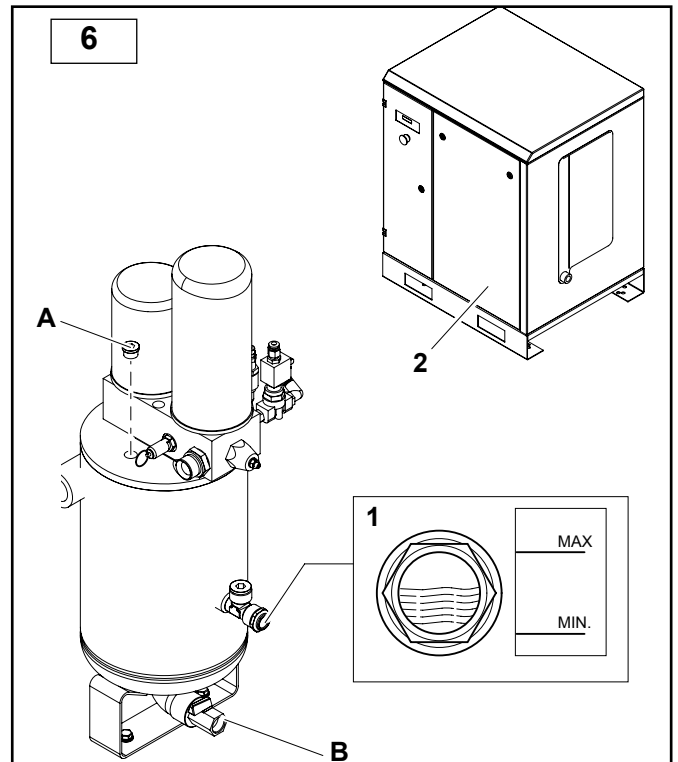

REPLACING THE OIL

When the compressor is hot - above 70 °C, replace the oil. **Alarm signal CH1**

- Remove the front panel
- Connect the drain hose provided to cock **B** located at the base of the separator tank.
- Unscrew the plug from hole **A**, open the cock and allow the oil to drain in to a container until draining is complete.
- Close cock **B** and withdraw the hose.
- Refill with new oil using hole A (quantity for complete refilling: 5 litres) and refit the plug.
- Start up the compressor and allow to function for 5 minutes, and then shut it down. Discharge all of the air and wait 5 minutes before controlling the oil level. Top up, if necessary.

THE EXHAUSTED OIL IS HIGHLY POLLUTANT! For its disposal comply with the current laws on environmental protection. The oil in the original equipment is FSN Original Oil in the following list:

Description	Type of oil
RotEnergyPlus 46cST	Synthetic lubricant ISO 46 for industrial use
RotEnergyFood 46cST	Synthetic lubricant ISO 46 for foodstuff use

A label attached to the compressor tank indicates the exact type of oil used before first installation.

You are advised to use that type of oil in all the oil changes planned for ordinary maintenance (for the time intervals, refer to the maintenance table). In the case of changing the type of oil, operate only for the complete replacement.

NEVER MIX DIFFERENT TYPES OF OIL.

In this case, change also the oil filter and the separator filter.

CHECKING THE TRANSMISSION BELT TENSION (Fig.9)

When the compressor is stopped, remove the rear panel and check the belt tension. Use a suitable measuring instrument that determines with precision the belt tension degree by means of a frequency measuring device in order to perform this control.

Operate as follows:

- Place the microphone of the measuring instrument near to the belt (about half way) and hit the belt with a wrench.
- Read the value detected by the instrument and if different from the values indicated in the table (fig.9A), adjust the tension:

Value higher = belt too tight

Value lower = belt too loose

Adjust by loosening the four bolts and adjust the tension with screw **C2**. After adjusting, tighten the bolts **C1**.

Check the frequency value again and if necessary, repeat the operation.

After replacing, check the belt tension as described previously.

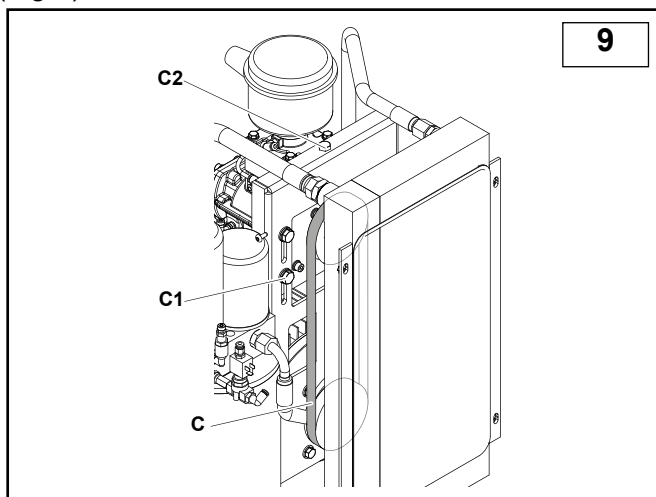

REPLACING THE TRANSMISSION BELT (Fig.9)

When the compressor is stopped, remove the rear panel. Loosen the four bolts **C1** and act on screw **C2** loosening belt **C** until completely loose.

Remove the belt and replace it with a new one.

Having made the replacement, after the first 30 minutes of operation, stop the machine, wait approximately 30 minutes (cooling) and check tightening of the belts as previously described.

Belt tension

REPLACING THE MINIMUM VALVE (Fig.10)

Replace the seals highlighted with the letter **G**.

REPLACING THE FLEXIBLE HOSES

It is recommended that they are replaced when changing the oil.

Loosen the hose fittings, replace them and tighten with force the fittings. Continue with the final phases of the oil changing procedure.

Working pressure (bar)	8	11	15	16	kW
8	74	84	92	101	Tension frequency Hz
10	78	87	93	104	
13	78	91	100	108	

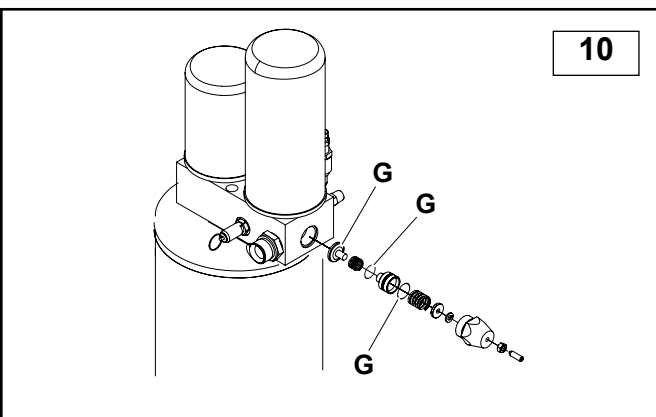

TROUBLESHOOTING



Problem	Cause	Remedy
Motor stopped (thermal relay operation signal)	Voltage too low	Check voltage, press Reset and then restart.
	Overtemperature	Check motor absorption and relay setting. In case of regular absorption press Reset and restart.
Oil consumption high	Drainage faulty	Check oil drain hose and check valve
	Oil level too high	Check oil level and drain some, if necessary
	Oil separator filter broken	Replace oil separator filter
	Oil separator filter seal leaking	Replace oil separator nipple seals
Intake filter leaks oil	Intake regulator stays open	Check regulator and solenoid valve
Safety valve opening	Pressure too high	Check the pressure settings.
	Intake regulator does not close at the end of the cycle	Check regulator and solenoid valve
	Oil separator filter clogged	Replace oil separator filter
Sensor for compressor temperature triggered	Room temperature too high	Improve ventilation
	Radiator clogged	Clean radiator with solvent
	Oil level too low	Top up oil
	Cooling fan does not start	Check the electric fan motor.
Compressor performance low	Air filter dirty or clogged	Clean or replace filter
Compressor does not compress air while running	Regulator closed. It cannot open because dirty.	Remove intake filter and check for proper manual opening. Remove and clean, if necessary.
	Regulator closed. It cannot open because no command is received.	Check for signal on solenoid valve. Replace damaged part, if any.
Compressor compresses air over max. pressure value	Regulator open. It cannot open because dirty.	Remove and clean regulator
	Regulator open. It cannot open because no command is received.	Check for signal availability between pressure switch and solenoid valve. Replace damaged part, if any.
Compressor does not start	Oil separator filter clogged	Replace oil separator filter
	Min. pressure valve does not close perfectly	Remove the valve, clean and replace seal, if necessary
Compressor hardly starts	Voltage too low	Check mains voltage
	Tube leaking	Tighten fittings

WIRING DIAGRAM

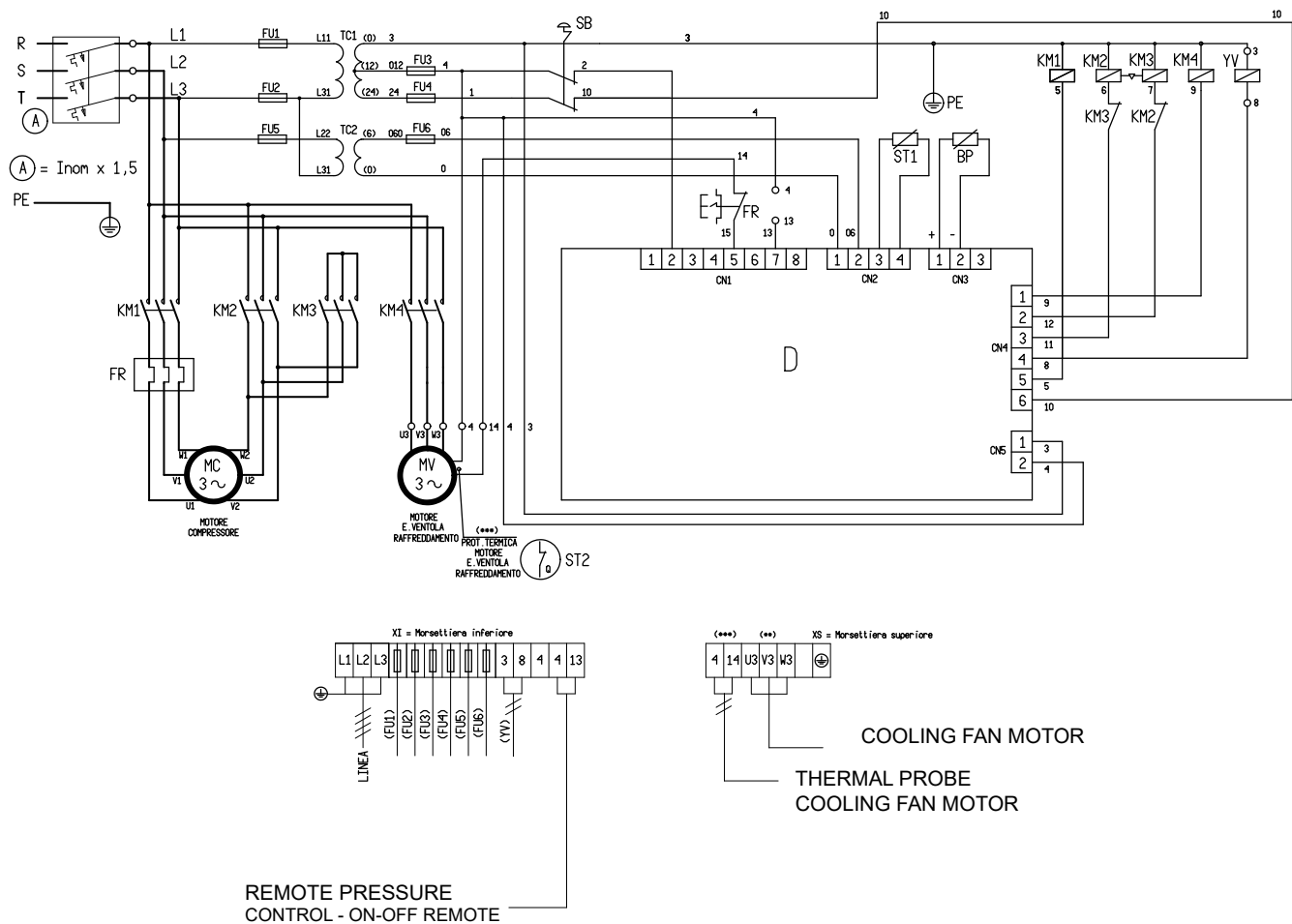

Ref.	Denomination	8		11		15 - 16	
		230 V	400 V	230 V	400 V	230 V	400 V
TC1	Transformer Pr.0/230/400 Sec.0/12/24	100 VA	100 VA	100 VA	100 VA	150 VA	100 VA
TC2	Transformer Pr.0/230/400 Sec.0/6						
SB	Emergency button + n.2 NC 230V 10A						
FU1.FU2.FU4	Ceramic fuses 6.3 x 32 GF 4A 500V						
FU3.FU5	Ceramic fuses 6.3 x 32 GF 1A 500V						
FU6	Ceramic fuse 6.3 x 32 GF 500mA 500V						
KM1	Coil line hour counter .24 V 50/60 Hz	11 kW(*)	5,5 kW(*)	11 kW(*)	7,5 kW(*)	18,5 kW(*)	11 kW(*)
KM2	Coil triangle hour counter.24 V 50/60 Hz	11 kW(*)	5,5 kW(*)	11 kW(*)	7,5 kW(*)	18,5 kW(*)	11 kW(*)
KM3	Coil star hour counter.24 V 50/60 Hz	7,5 kW(*)	4 kW(*)	11 kW(*)	7,5 kW(*)	15 kW(*)	7,5 kW(*)
KM4	Contactore cooling solenoid valve 24 V 50/60 Hz	3 kW(*)	3 kW(*)	3 kW(*)	3 kW(*)	3 kW(*)	3 kW(*)
FR	Thermal- reset MAN/AUT - 1L+1R	(14-20)	(9-12,5)	(20-25)	(11-16)	(30-36)	(17-22)
YV	Electric valve 24 VAC 50/60 Hz 8VA						
BP	Pressure transducer 0-16 Bar 4-20mA						
D	Electronic control 12VAC						
ST1	Thermal probe						
MV	Motor E. Cooling fan 230/400V 50/60 Hz	180 W	180 W	180 W	180 W	180 W	180 W
	Motor cable cross-section (mmq)	7x4	7x2,5	7x6	7x2,5	7x10	7x4

- 1) Aux. section = 1mmq
- 2) (*) = 400V AC3
- 3) (**) = 400 V
- VOLTAGE - BLACK-BLUE-BROWN
- YELLOW-GREEN-WHITE BRIDGE
- 230V
- VOLTAGE. - (BROWN-WHITE) / (BLUE-GREEN)/(BLACK-YELLOW)

